

## Bearingizing tools

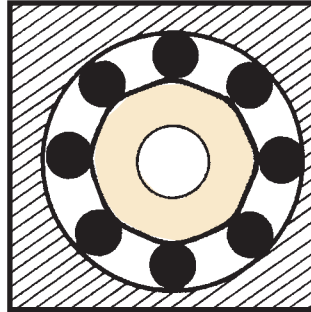

*The Bearingizing Tool combines roller burnishing with peening action. As the tool is rotated at a high speed the rolls spin, rise, and fall over a cammed arbor, delivering up to 200,000 rapid fire blows per minute to the work surface. The peaks and valleys of the machined surface are compacted into a smooth, hardened, and ultrafine surface finish.*

The Bearingizer *may* be the tool of choice where the following conditions exist:

- Parts with *thin walls* — Bearingizing eliminates barrel-shaping of the part.
- Parts with *irregular wall thicknesses* — the Bearingizing tool will produce a very round hole, whereas the Roll-a-Finish® tool might generate a slightly egg-shaped hole, due to variations in wall thickness.
- Applications where *porosity* is an issue (e.g., oil-impregnated bearings) — the smaller “footprint” of the Bearingizing roll leaves pores in the surface intact.
- Applications where *very tight tolerances* must be held — the Bearingizer reduces springback in the work surface material. The Bearingizing tool can, in some materials and with proper part preparation, hold size as close as  $\pm .0001$  inch (.002mm), while the Roll-a-Finish tool can achieve tolerances of  $\pm .00025$  inch (.006mm).

Where the above conditions do *not* exist, the Roll-a-Finish® tool would generally be the tool of choice, for two reasons:

- (1) the relatively wide adjustment range of the Roll-a-Finish tool, which is typically .040 inch (1.01mm), and
- (2) the ease of adjustment, with the castellated adjusting collar on the Roll-a-Finish tool.

The Bearingizing tool features a greater number of rolls, and rolls of a smaller diameter, as compared to the Roll-a-Finish tool, and can only be adjusted by change of rolls. The Bearingizer also requires a closer presize than the Roll-a-Finish tool.

But where the above conditions *do* exist, the Bearingizing tool should be considered.

While the Roll-a-Finish Tool increases surface hardness by about 5 to 10%, Bearingizing increases hardness by 10 to 30%, but with less surface penetration.



# Tool specifications

Bearingizing tools provide three roll positions over the cammed arbor (see below). When the forward (#1 position) of cam becomes worn, the roll cage can be repositioned to the # 2 and # 3 positions by exchanging positions with the moveable collars. This presents NEW cam surfaces and original BUILD-UP. After all positions

on the cam are worn beyond producing acceptable parts, oversize rolls can be used to further extend tool life. Roll sizes are available in increments of .0001 inch (.0025 mm) and the tool will accommodate a range of roll sizes up to .002 inch (.0508 mm).

For through-hole, semi-bottoming, or bottoming applications.

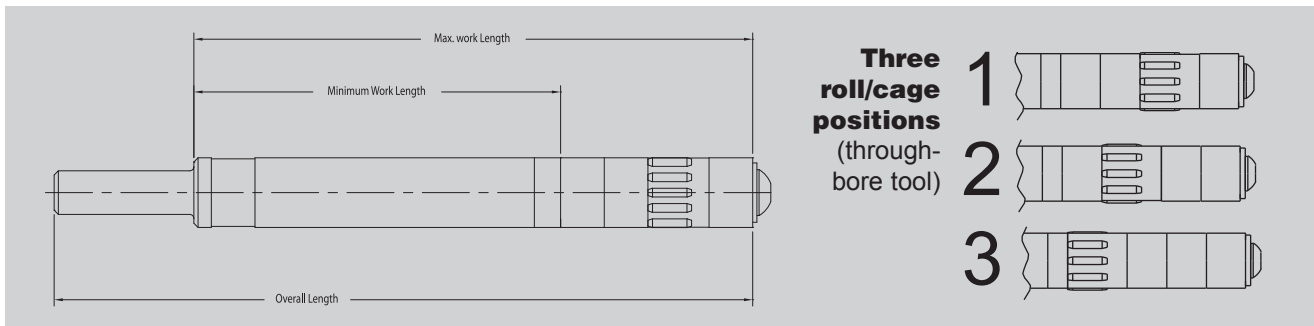

## Bearingizing Tools .188 to 1.250 in. (4.76 to 31.75mm)

NOMINAL TOOL SIZE		BUILD-UP RANGE		CAM DIAMETER		SHANK	OVERALL LENGTH		WORK LENGTH				NO. OF ROLLS
INCHES	MM	INCHES	MM	INCHES	MM		INCHES	MM	MAXIMUM		MINIMUM		
									INCHES	MM	INCHES	MM	
.188	4.76	.1861 .1901	4.727 4.829	.1281	3.254	↑	5.5	139.7	2.938	74.61	2.188	55.56	6
.219	5.56	.2174 .2214	5.522 5.624	.1594	4.049			5.5	139.7	2.938	74.61	2.188	55.56
.236	6	.2343 .2383	5.951 6.053	.1670	4.242		6	152.4	3.438	87.31	2.375	60.32	6
.250	6.35	.2486 .2526	6.314 6.416	.1806	4.587		6	152.4	3.438	87.31	2.375	60.32	6
.276	7	.2743 .2783	6.967 7.069	.2064	5.243		6	152.4	3.438	87.31	2.313	58.74	6
.281	7.14	.2799 .2839	7.109 7.211	.2119	5.382		6	152.4	3.438	87.31	2.313	58.74	6
.313	7.94	.3112 .3152	7.904 8.006	.2212	5.618		6	152.4	3.438	87.31	2.313	58.74	6
.315	8	.3137 .3177	7.968 8.069	.2238	5.667	.500 in. DIA. or	6	152.4	3.438	87.31	2.313	58.74	6
.343	8.73	.3425 .3465	8.700 8.801	.2525	6.414			7	177.8	4.438	112.71	3.063	77.79
.354	9	.3530 .3570	8.966 9.068	.2631	6.683	12mm DIA.	7	177.8	4.438	112.71	3.063	77.79	6
.375	9.53	.3738 .3778	9.495 9.596	.2518	6.396		7	177.8	4.438	112.71	3.125	79.38	6
.394	10	.3965 .3925	9.970 10.071	.2705	6.871		7	177.8	4.438	112.71	3.125	79.38	6
.406	10.32	.4051 .4091	10.290 10.391	.2831	7.191		8	203.2	5.438	138.11	3.563	90.49	6
.433	11	.4320 .4360	10.973 11.074	.2779	7.059		8	203.2	5.438	138.11	3.688	93.66	6
.438	11.11	.4365 .4405	11.087 11.189	.2825	7.176		8	203.2	5.438	138.11	3.688	93.66	6
.469	11.91	.4678 .4718	11.882 11.984	.3138	7.971		8	203.2	5.438	138.11	3.688	93.66	8
.472	12	.4710 .4750	11.963 12.065	.3174	8.062	↓	8	203.2	5.438	138.11	3.688	93.66	8

# Tool specifications

## Bearingizing tools

Bearingizing Tools .188 to 1.250 in. (4.76 to 31.75mm) *continued*

NOMINAL TOOL SIZE		BUILD-UP RANGE		CAM DIAMETER		SHANK	OVERALL LENGTH		WORK LENGTH				NO. OF ROLLS
INCHES	MM	INCHES	MM	INCHES	MM		INCHES	MM	MAXIMUM		MINIMUM		
									INCHES	MM	INCHES	MM	
.500	12.70	.4990 .5030	12.675 12.776	.3450	8.763	↑	8	203.2	5.438	138.11	3.688	93.66	8
.512	13	.5110 .5150	12.979 13.081	.3568	9.063	.500 in. DIA.	8	203.2	5.438	138.11	3.688	93.66	8
.531	13.49	.5303 .5343	13.470 13.571	.3763	9.558	or	8	203.2	5.438	138.11	3.688	93.66	8
.551	14	.5500 .5540	13.970 14.072	.3962	10.063	12mm DIA.	8	203.2	5.438	138.11	3.688	93.66	8
.563	14.29	.5615 .5655	14.262 14.364	.4075	10.351	↓	8	203.2	5.438	138.11	3.688	93.66	8
.591	15	.5936 .5896	15.077 14.976	.4356	11.064	↑	8	203.2	4.875	123.83	3.125	79.38	8
.594	15.09	.5928 .5968	15.057 15.159	.4388	11.146		8	203.2	4.875	123.83	3.125	79.38	8
.625	15.87	.6240 .6280	15.850 15.951	.4390	11.151		8	203.2	4.875	123.83	3.125	79.38	8
.630	16	.6290 .6330	15.977 16.078	.4439	11.275		8	203.2	4.875	123.83	3.125	79.38	8
.656	16.67	.6553 .6593	16.645 16.746	.4703	11.946		8	203.2	4.875	123.83	3.125	79.38	8
.669	17	.6680 .6720	16.967 17.069	.4833	12.276		8	203.2	4.875	123.83	3.125	79.38	8
.688	17.46	.6865 .6905	17.437 17.539	.5015	12.738		8	203.2	4.875	123.83	3.125	79.38	8
.709	18	.7080 .7120	17.983 18.085	.5227	13.277	.750 in. DIA.	8	203.2	4.875	123.83	3.125	79.38	10
.719	18.26	.7178 .7218	18.232 18.334	.5328	13.533	or	8	203.2	4.875	123.83	3.125	79.38	10
.748	19	.7470 .7510	18.974 19.075	.5620	14.275	20mm DIA.	8	203.2	4.875	123.83	3.125	79.38	10
.750	19.05	.7490 .7530	19.025 19.126	.5640	14.326		8	203.2	4.875	123.83	3.125	79.38	10
.781	19.84	.7803 .7843	19.820 19.921	.5953	15.121		8	203.2	4.875	123.83	3.125	79.38	10
.787	20	.7860 .7900	19.964 20.066	.6014	15.276		8	203.2	4.875	123.83	3.125	79.38	10
.813	20.64	.8115 .8155	20.612 20.714	.6265	15.913		8	203.2	4.875	123.83	3.125	79.38	10
.827	21	.8260 .8300	20.980 21.082	.6408	16.276		8	203.2	4.875	123.83	3.125	79.38	10
.844	21.43	.8428 .8468	21.407 21.509	.5958	15.133		9	228.60	5.875	149.23	3.75	95.25	10
.866	22	.8650 .8690	11.971 22.076	.6181	15.700		9	228.60	5.875	149.23	3.75	95.25	10
.875	22.22	.8740 .8780	22.200 22.301	.6270	15.926	↓	9	228.60	5.875	149.23	3.75	95.25	10
.905	23	.9050 .9090	22.987 23.087	.6583	16.721	↑	10	254.00	6.125	155.58	4.00	101.60	10
.906	23.02	.9053 .9093	22.995 23.096	.6583	16.721		10	254.00	6.125	155.58	4.00	101.60	10
.938	23.81	.9365 .9405	23.787 23.889	.6895	17.513		10	254.00	6.125	155.58	4.00	101.60	10
.945	24	.9440 .9480	23.978 24.078	.6969	17.701	1.000 in. DIA.	10	254.00	6.125	155.58	4.00	101.60	10
.969	24.61	.9678 .9718	24.582 24.684	.7208	18.308	or	10	254.00	6.125	155.58	4.00	101.60	12
.984	25	.9830 .9870	24.968 25.070	.7363	18.702	25mm DIA.	10	254.00	6.125	155.58	4.00	101.60	12
1.000	25.40	.9990 1.0030	25.375 25.476	.7520	19.101		10	254.00	6.125	155.58	4.00	101.60	12
1.063	26.99	1.0615 1.0655	26.962 27.064	.8145	20.688		10	254.00	6.125	155.58	4.00	101.60	12
1.125	28.57	1.1240 1.1280	28.550 28.651	.8770	22.276		10	254.00	6.125	155.58	4.00	101.60	12
1.188	30.16	1.1865 1.1905	30.137 30.239	.9395	23.863		10	254.00	6.125	155.58	4.00	101.60	12
1.250	31.75	1.2490 1.2530	31.725 31.826	.9390	23.851	↓	10	254.00	6.125	155.58	4.00	101.60	14

*Shanks other than shown above are available upon request.*

# Selection & ordering information

To select a tool for the part and material to be Bearingized, determine the proper tool *build-up*. The build-up is the effective tool diameter required to produce a certain size in a given material. It is measured with the rolls diametrically opposed on the high surfaces of the cam.

The build-up is equal to the maximum finished hole diameter plus a spring-back allowance — see chart. The maximum diameter (high side of tolerance) is used to allow for tool wear and still maintain part size within tolerance limits.

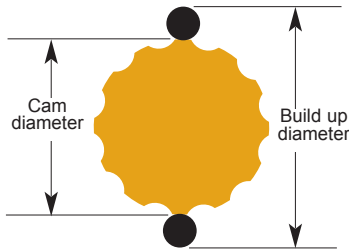

## Nominal tool sizes

The program is based on nominal diameters of .188 inch (4.76mm) through 1.250 inch (31.75mm). Each tool provides a build-up range of .004 inch (.1016mm). The required build-up must be within the range of the tool size shown — otherwise select an intermediate tool. See ordering information at right.

### EXAMPLE

Stainless Steel part  
 .5010/.5008 inch  
 (12.725/12.720mm) tolerance .5010  
 Add Stainless Steel spring-back allowance +.0010  
 Build-up .5020

Since a .5020 inch (12.75mm) build-up falls within a range of .4990-.5030 inch (12.67-12.78mm), order a nominal .500 inch (12.7mm) through-hole Bearingizing tool and rolls ... or order through-hole Bearingizing tool with .5020 inch (12.75mm) build-up — Cogsdill will furnish proper tool and rolls.

## Roll Sizes

To determine the roll size for a standard tool, subtract the cam diameter from the build-up and divide by two (2). This establishes the single roll diameter.

### EXAMPLE

Build-up required for part .5020 inch (12.75mm)  
 Subtract cam diameter of .500 inch (12.75mm) tool  $-.3450$  inch (8.76mm)  
 $.1570$  inch (3.99mm)  
 Divided by 2  $.1570$  inch  $\div 2 = .0785$  inch (1.99mm)  
 Single roll size .0785 inch (1.99mm)

Order .500 inch (12.7mm) Bearingizing tool with .0785 inch (1.99mm) rolls.

Spring-Back Allowances	.188 to .500 (4.76 to 12.7 mm)		.500 & up (12.7 mm & up)	
	IN.	mm	IN.	mm
Stainless	.0008	.0203	.001	.0254
Steel	.0008	.0203	.001	.0254
Cast Iron	.0005	.0127	.0008	.0203
Sintered Iron	.0005	.0127	.0008	.0203
Aluminum	.0002	.0050	.0004	.0102
Brass	.0005	.0127	.0008	.0203
Sintered Bronze	.0001	.0025	.0002	.0051
Oilite	.0001	.0025	.0002	.0051

*Note: Above are recommended starting points only. Final build-up can best be determined by actual trial and several extra sets of rolls in increments of .0001 inch (.0025mm) are recommended.*

## Ordering nominal tool sizes

1 Specify tool size and roll diameter, or specify hole size and material.

2 Specify tool style: through-hole, semi-blind or blind-hole tool. Through-hole tools use chamfered rolls; semi-blind or blind-hole tools use radius rolls. Blind-hole tools have a special roll retainer which permits finishing within .025 inch (.635mm) of the bottom.

3 Extra sets of rolls in increments of .0001 inch (.0025mm) are recommended with initial orders to allow for final size adjustment and compensate for eventual tool wear.

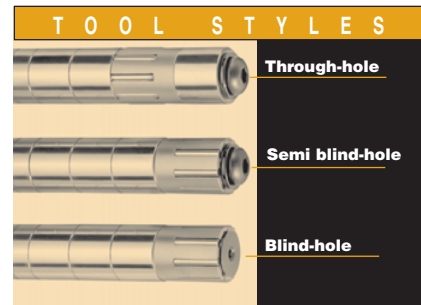

## Ordering intermediate and larger tools

### Intermediate sizes

Sizes that do not fall within the range of nominal tools are ordered by build-up only. Cogsdill will design tool and specify roll size.

### Tools over 1.250 inch (31.75mm) in diameter

Order by build-up diameter. Cogsdill will design tool and specify roll size. We suggest that part print be furnished with inquiry. This will enable Cogsdill engineers to quote on any special features that may be desirable, such as extended front pilot, etc.

## Re-ordering tools and parts

Re-order nominal size tools and parts by fractional tool size shown on shank—except roll sizes, which should be determined by the required build-up. Re-order intermediate and larger size tools and parts, including rolls by BT number shown on shank. If cams are worn, larger rolls may be required (available in increments of .0001 inch (.0025mm)). Cogsdill will also re-grind cams and supply rolls to maintain original build-up.

# Operation & maintenance

## Machines

Any machine capable of rotating the tool — e.g. drill press, speed lathe, or turret lathe — may be used.

## Material

Any ductile or malleable material — powdered, laminated, cast, forged, extruded, sintered or hardened (maximum Rc 38) can be bearingized. Steel, stainless, alloy, cast iron, aluminum, copper and brass are examples.

## Procedure

Proper part preparation is essential in order to obtain precise results. Cogsdill will recommend the surface preparation and amount of stock to leave for Bearingizing, but some trials may be required to determine these factors for optimum results.

Since the change in dimension is partly governed by the character of the prepared surface, usually coarser preparation will permit a greater change in dimension than is possible with finer preparation. The consistent pattern obtained from boring will produce the best finish.

The other major factor in dimensional change is the ability of

the material to grain-flow without flaking. The total change may vary from .0001 inch (.0025mm) on harder materials to as much as .003 inch (.0762mm) on sintered self-lubricating bushings. Less than .001 inch (.0254mm) stock for Bearingizing generally provides a good starting point for trials.

## Tool diameter changes

Bearingizing rolls are manufactured in increments of .0001 inch (.0025mm). Bearingizing Tools are adjustable by roll change only. One set of rolls can be removed and a new set of a different size installed, thus effectively changing the size of the tool — or compensating for tool wear. The working diameter of any tool can be changed over an approximate .004 inch (.1016mm) range by installing different sets of rolls. The rolls are diametrically opposed and available in .0001 inch (.0025mm) increments, therefore the effective tool diameter can be changed in .0002 inch (.0051mm) increments.

## Lubrication

For most metals use any standard grade of lightweight, low viscosity lubricating oil, or any mineral, sulphur or soluble oil that is compatible with the alloy or metal to be burnished and is recommended for fine surface finishing.

For aluminum or magnesium alloys, use a highly refined oil-based coolant with low viscosity.

For cast iron a mineral seal or water soluble solution is ideal — flooding the part is recommended.

## Cleaning

The Bearingizing tool should be cleaned periodically with a light-bodied oil of about 100 Saybolt universal scale, similar to a light spindle oil. A few drops applied with squirt can or brush to the rolls and cage (with cage stopped) will wash metal dust particles out when tool is operated, keeping the cam surfaces and roll pockets clean.

## Speed and feed recommendations

HOLE DIAMETER		RPM	HOLE DIAMETER		RPM	HOLE DIAMETER		RPM	HOLE DIAMETER		RPM
INCHES	MM		INCHES	MM		INCHES	MM		INCHES	MM	
.188	4.762	8200	.750	19.050	2000	1.750	44.45	875	2.750	69.85	555
.250	6.350	6100	.875	22.225	1800	1.875	47.62	815	2.875	73.02	530
.312	7.937	4900	1.000	25.40	1500	2.000	50.80	765	3.000	76.20	510
.375	9.525	4100	1.125	28.57	1350	2.125	53.97	720	3.500	88.90	435
.437	11.112	3500	1.250	31.75	1200	2.250	57.15	680	4.000	101.60	380
.500	12.700	3100	1.375	34.92	1100	2.375	60.32	645	4.500	114.30	340
.562	14.287	2700	1.500	38.10	1000	2.500	63.50	610	5.000	127.00	305
.625	15.875	2400	1.625	41.27	950	2.625	66.67	580	5.500	139.70	280

*FEED—Feed Rate in and out should be quite rapid, 150-250 inches per minute (3.81M-6.35M), rather than slow.*

*The speeds and feeds recommended are for best tool life.*

*The same results can be achieved at slower rate, but with some sacrifice of tool life.*