

# Generating Heads

For facing, recessing, boring, and contouring. Multiple operations can be performed faster, more economically, with better quality, and at one spindle location. Used on special-purpose machines and other high production machinery, including transfer lines and dial machines.

- Single or double-slide models are available, designed for feed-out or feed-in
- Sizes from 100 to 250mm (3.937 to 9.842 in.) in diameter
- Drawbar actuation- no need to pilot in part or fixture
- Unique actuator design- smooth, accurate motion for precise repeatability
- Internal mechanism manufactured to exacting tolerances- backlash is virtually eliminated
- All moving parts are hardened and precision ground for lasting accuracy
- Built-in lubeways and easily accessible grease fittings
- Equipped with through-tool auto lube capability
- Special lightweight slides are available (optional) for higher cutting speeds and shorter cycle times- tooling can be balanced

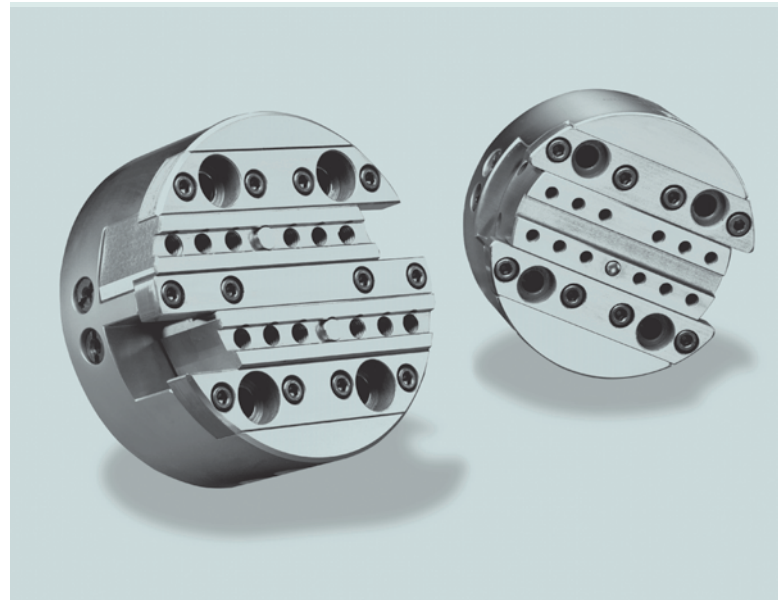

Custom-designed top tooling is mounted in qualified holes on the tool slide. Standard inserts are used for most applications. Special head designs and special form cutters are available.

Cogsdill generating heads are designed to work on machines where the tool slide stroke is controlled by a drawbar. The drawbar can produce finite, accurate movements in the tool slide(s), allowing the head to perform accurate machining operations. Drawbars can either push or pull on the actuator, and may be controlled by CNC, hydraulic, or mechanical action.

Operations such as boring, turning, facing, chamfering, and form cutting can be easily performed. Generating heads can often be made to perform multiple operations in a single pass – this provides for optimum efficiency and performance in your machining operations.

Cogsdill generating heads are made from the highest quality materials, to exacting quality standards. Our engineers have built in quality features that ensure durability and consistent accuracy. These high-quality features include hardened and ground components, multiple grease fittings with internal lube ways, and anti-friction coatings on wear surfaces.

# Operating Principle

## Generating HEADS

The method of operation incorporated in all Cogsdill generating heads is based on the principal of a sliding inclined wedge. This actuation mechanism produces smooth, linear cutter movement with little or no backlash.

Cogsdill generating heads can be utilized on a variety of drawbar-equipped machines such as transfer lines, rotary transfer (dial type) machines, and other special purpose machines. The heads can be mounted on virtually any spindle that has a drawbar. Cogsdill can provide a complete tooling package for new machines, as well as for retrofitting an existing machine.

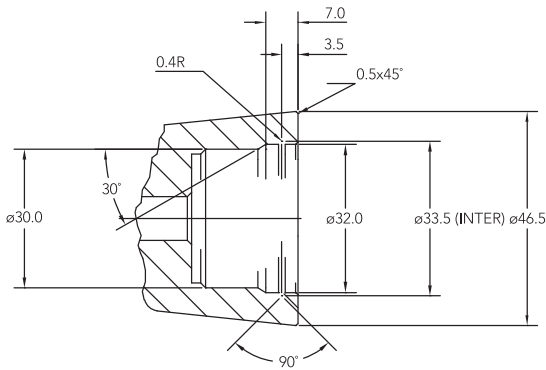
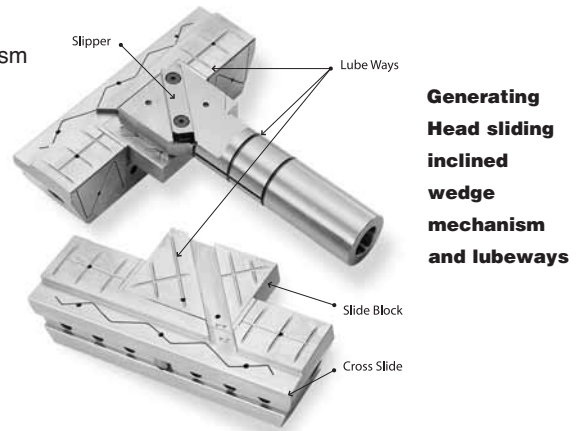

This typical component requires three machining operations: a face, an I.D. groove, and an O.D. chamfer. All operations will be completed at one station with one pass of the Cogsdill generating head. Drawbar stroke on the machine will control cutter movement.

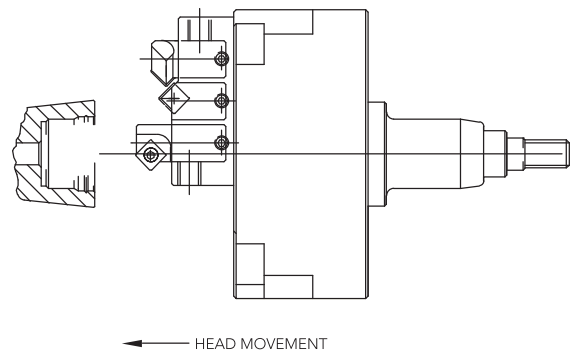

**1** The part is in position. The rotating machine spindle moves the generating head toward the part to begin the operation sequence. The drawbar and cross slide are in the home position.

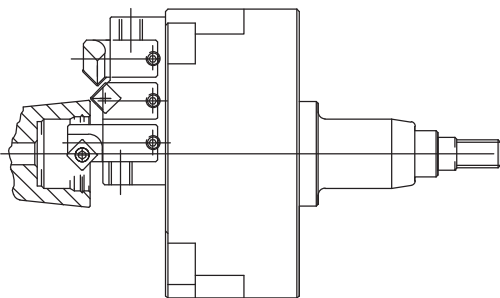

**2** The head is now in position. The drawbar begins to pull, causing the cross slide and cutters to move radially across the part as the cutting stroke begins. The face is cut first, followed by the I.D. groove, and then the O.D. chamfer.

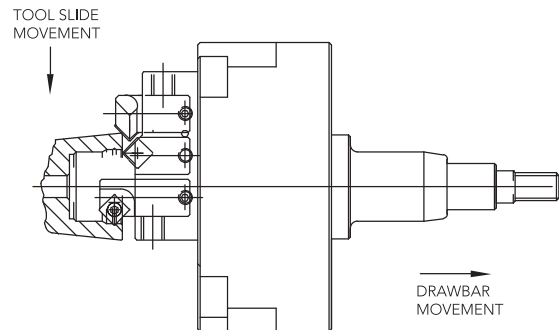

**3** The head is now at full drawbar stroke, and the cuts have been completed. The drawbar is then pushed back to the home position, thereby retracting the cutters. The spindle then retracts and the head is pulled away from the part and returned to the position shown in step one.

Cogsdill generating heads are available as standard products in single-slide and double-slide models, ranging in diameter from 100mm to 250mm (approximately 4 to 10 inches). The head type used generally depends on the operation(s) being performed and the speed at which the head is run. Top tooling packages can be designed by our engineers to suit individual requirements. Specially designed heads are available when required to meet unique part requirements or production challenges.

### Auto-lube

Our auto-lube feature enhances the longevity of the generating head by ensuring that all parts are consistently lubricated. Every Cogsdill generating head comes with auto-lubrication capability as a standard feature. Lubrication is fed to the head through the drawbar and actuator shaft. This feature can add many thousands of cycles to the life of the head, while eliminating the need to perform manual lubrication on a daily basis. Installation is easy on machines with spindles that have through-lube capability.

Most commercial auto-lube systems installed on machines are more than adequate for use with Cogsdill generating heads. The heads are usually lubricated automatically several times per shift, depending on the type of lubrication system available. When used in conjunction with an oil mist system (ISO68 grade oil), the flow rate is usually adjusted to a moderately low setting. For specific questions regarding the auto-lube feature, please consult with our engineering group.

### Lubrication Recommendations

All heads may be manually lubricated via grease fittings in the main body if a through-lube system is not available on your machine. If these heads are not used with an automatic lubrication system, it is necessary to manually lubricate them at least weekly. More frequent lubrication may be necessary depending on the operational speed, type of coolant used, rapid cycling, and other factors. **Kluber Altemp Q NB50** has been thoroughly tested and found to perform exceptionally well – it is the only grease we recommend. Using a grease gun, inject one or two pumps of grease into each grease fitting.

**Remember, adequate lubrication is vital to long head life and trouble-free performance.**

It is also recommended that **Kluber Altemp Q NB50** grease be applied to all moving parts and surfaces when the head is disassembled for maintenance and cleaning, or if the head is to be stored for extended periods.

**(Note: if the head is being used with an oil mist automatic lube system, do not use the Kluber grease during disassembly and cleaning. Instead, use the same recommended ISO68 oil that is fed through the lube system. It is important not to mix the oil and grease – only one type of lubrication should be used at any one time.)**

A high-pressure hand pump gun is available from Cogsdill to make routine maintenance easy. (Ref. Part No. CN-D24)

### Actuation Ratios

The standard actuation ratio for our heads is based on a 40-degree actuation angle. Slide travels for the standard actuation ratio are shown in the specification charts on the following pages.

Special actuation ratios are available to accommodate unique applications (e.g., when an extremely short tool stroke is required). Please consult with our engineering group when a non-standard ratio is required.

### Adapter Plates

The bolt pattern in Cogsdill generating heads will fit a variety of spindles. However, when using a standard head, it may be necessary to use an adapter plate to mount the head due to different bolt patterns in the head and spindle. Cogsdill can design and manufacture adapter plates, when needed, to ensure accurate mounting of the head on any spindle. Special bolt patterns can also be built into specially designed heads.

### Top Tooling Packages/Counterbalance Weights

Cogsdill can provide full top tooling packages for your application. Standard ISO / ANSI inserts are used where possible. Special form inserts are supplied where required.

When using a double-slide head, the slides move in opposing directions. This allows the head to be balanced by mounting a counterbalance to the slide opposite the one with the cutting tool. The weight moves proportionately to the cutting edge, thus producing a balanced cut. (In double-slide applications where tooling is mounted on both slides, the tooling can be balanced.) Balance is particularly important as the size of the head, or the rotational speed, increases. The head can be dynamically balanced to a specific cut diameter and speed. (Single-slide heads are generally not balanced).

(continued)

### Drawbar Force Requirements

The drawbar force required to actuate the generating head is dependent upon three variable but interrelated factors:

- Size of generating head
- Spindle speed or cycle time requirement
- Weight of top tooling

As the size of the head increases, so does the required drawbar force. Cycle time requirements can also directly affect the spindle speed. In some cases, the use of high strength aluminum alloy cross slide(s) and/or top tooling may be necessary to keep the drawbar force requirements within the operational limits of the machine (see next section below).

**Due to variations in top tooling weight, it is difficult to predict the actual drawbar force required to operate a generating head in a given application until a thorough layout is completed. When submitting a generating head application for quotation, please provide the following information in addition to part prints and general machine specifications:**

- Spindle speed range available for your machine
- Desired cycle time (if known) for the operation(s) to be performed
- Drawbar actuation method (i.e. mechanical, CNC, or hydraulic) and force available

**Our engineering department will recommend the appropriate generating head, and will quote a complete tooling package to suit your requirements.**

### Lightweight Cross Slides and Top Tooling

When application requirements demand head operation at higher than normal speeds, Cogsdill engineers can specify a special lightweight, high strength, aluminum alloy for manufacturing cross slides and some top tooling. The use of this alloy reduces the rotational mass of the head, allowing the tool to be run at higher speeds without significantly affecting the drawbar force requirement for actuating the head.

### Requests for Quotation

All quote requests should be submitted through our customer service department.

**While most heads sold are standard heads, each application tends to be unique. In order for our engineers to prepare a formal and complete quotation, we need to know as much as possible about your application. In order to assure that we have the necessary data for quoting, please submit the following:**

- A copy of the Application Data Sheet in the back of this catalog, filled out as completely as possible (material type, operations required, how the parts will be fixtured, etc.).
- A complete part drawing, and machine and spindle data. Please include spindle speed range, drawbar actuation method, and available drawbar force (if known).

### Other important information includes:

- Does the application require a head that feeds in or feeds out?
- What actuation ratio is required (if known)? (If unknown, our engineers will gladly make recommendations.)
- Single or double slide?
- What type of drawbar fitting? (I.e. male or female, thread size and pitch. Male is standard, female is available on request.)
- Is through-lube capability available on the machine spindle?
- What is your production volume requirement?
- What is the desired machining cycle time for the operations involved (if known)?

**Our customer service personnel will be pleased to assist you in answering questions about your application.**

## Single-Slide Head

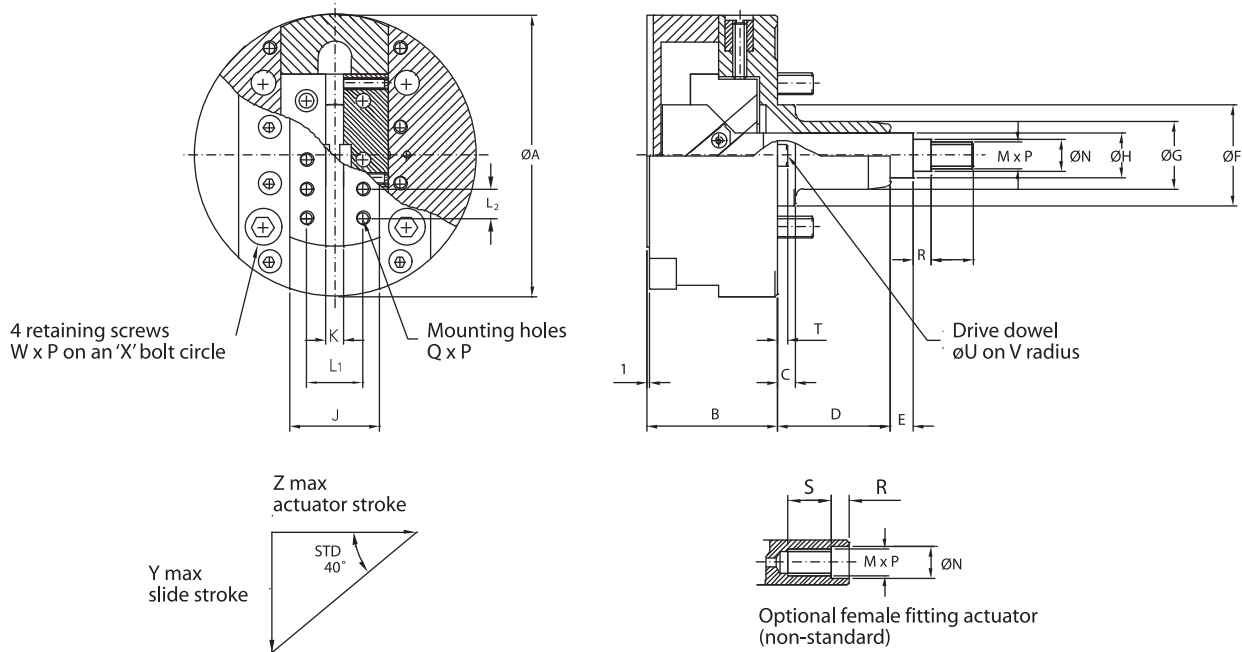

### INCH [METRIC]

HEAD TYPE	(A)	(B)	(C)	(D)	(E)	(Fh <sup>5</sup> )	(G)	(H)	(J)	(K <sup>H7</sup> x DP)	(L)	(L <sub>2</sub> )
CN100SA	3.937 [100]	1.969 [50]	0.236 [6]	1.772 [45]	0.394 [10]	1.260 [32]	0.984 [25]	0.630 [16]	1.181 [30]	0.315 x 0.118 [8 x 3]	0.669 [17]	0.433 [11]
CN125SA	4.921 [125]	2.283 [58]	0.315 [8]	1.969 [50]	0.394 [10]	1.772 [45]	1.181 [30]	0.787 [20]	1.575 [40]	0.315 x 0.118 [8 x 3]	0.984 [25]	0.512 [13]
CN160SA	6.300 [160]	2.756 [70]	0.374 [9.5]	2.362 [60]	0.394 [10]	3.937 [100]	1.378 [35]	0.984 [25]	1.969 [50]	0.394 x 0.157 [10 x 4]	1.181 [30]	0.630 [16]
CN200SA	7.874 [200]	3.346 [85]	0.472 [12]	2.756 [70]	0.394 [10]	5.315 [135]	1.969 [50]	1.260 [32]	2.756 [70]	0.472 x 0.157 [12 x 4]	1.772 [45]	0.787 [20]
CN250SA	9.843 [250]	3.937 [100]	0.591 [15]	3.543 [90]	0.394 [10]	6.300 [160]	1.969 [50]	1.260 [32]	3.543 [90]	0.472 x 0.157 [12 x 4]	2.362 [60]	0.787 [20]

### INCH [METRIC]

HEAD TYPE	(M x P/LH)	(N <sup>h7</sup> )	(Q x P)	(R)	(S)	(T)	(U <sup>m5</sup> )	(V)	(W x P)	(X)	(Y)	(Z)
CN100SA	M10 x 1.0	0.472 [12]	M5 x 0.8	0.315 [8]	0.669 [17]	0.197 [5]	0.315 [8]	1.575 [40]	M8 x 1.25	2.756 [70]	0.669 [17]	0.795 [20.2]
CN125SA	M12 x 1.5	0.551 [14]	M6 x 1.0	0.315 [8]	0.748 [19]	0.236 [6]	0.394 [10]	1.969 [50]	M10 x 1.50	3.543 [90]	0.866 [22]	1.031 [26.2]
CN160SA	M16 x 1.5	0.709 [18]	M8 x 1.25	0.394 [10]	0.984 [25]	0.256 [6.5]	0.472 [12]	2.559 [65]	M12 x 1.75	4.724 [120]	1.181 [30]	1.406 [35.7]
CN200SA	M16 x 1.5	0.709 [18]	M10 x 1.5	0.394 [10]	0.984 [25]	0.394 [10]	0.630 [16]	3.346 [85]	M12 x 1.75	6.300 [160]	1.575 [40]	1.878 [47.7]
CN250SA	M16 x 1.5	0.709 [18]	M12 x 1.75	0.394 [10]	0.984 [25]	0.472 [12]	0.787 [20]	3.937 [100]	M16 x 2.0	7.480 [190]	1.969 [50]	2.346 [59.6]

## Single-Slide Head

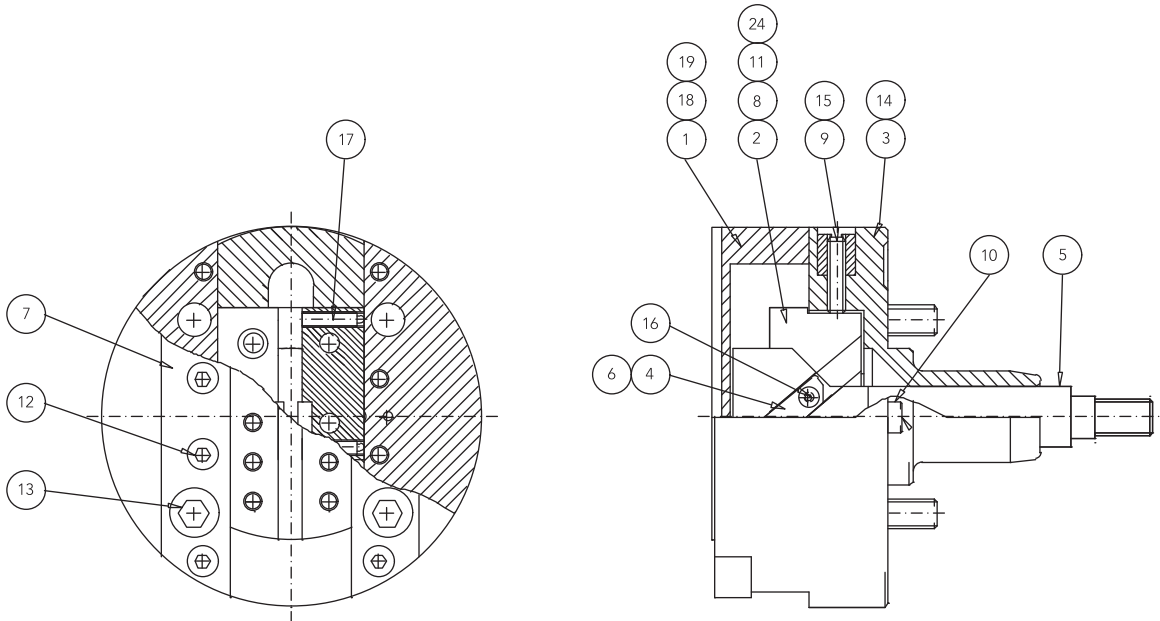

1 Cross-slide	7 Keeper Plate	13 Caphead Screw	19 Location Dowel
2 Slide Block	8 Slide Block	14 Grease Nipple	24 Spring Washer
3 Body	9 Locknut	15 Dog Point Screw	
4 Key	10 Drive Dowel	16 Head Screw	
5 Actuator	11 Lock Screw	17 Spring Plunger	
6 Key	12 Caphead Screw	18 Wiper	

## Double-Slide Head

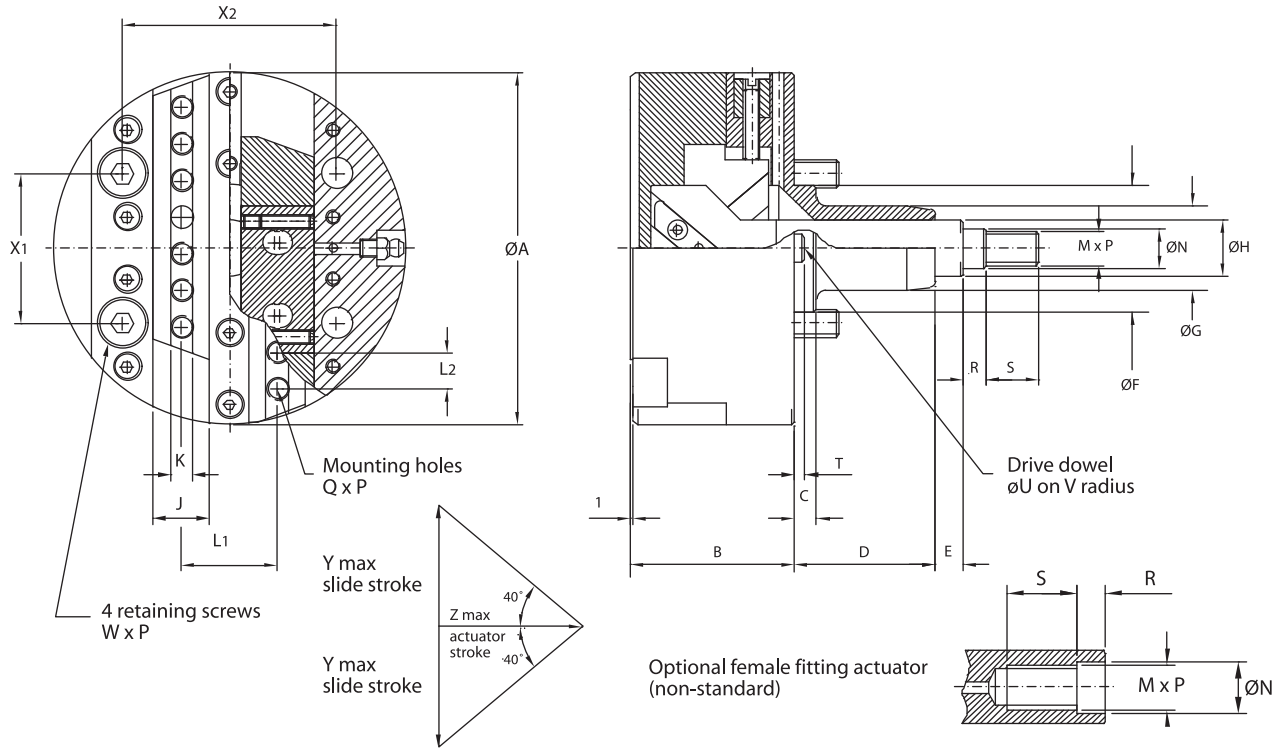

### INCH [METRIC]

HEAD TYPE	(A)	(B)	(C)	(D)	(E)	(Fh <sup>5</sup> )	(G)	(H)	(J)	(K <sup>H7</sup> x DP)	(L <sub>1</sub> )	(L <sub>2</sub> )
CN100DA	3.937 [100]	1.969 [50]	0.236 [6]	1.772 [45]	0.394 [10]	1.260 [32]	0.984 [25]	0.630 [16]	0.630 [16]	0.236 x 0.118 [6 x 3]	1.102 [28]	0.394 [10]
CN125DA	4.921 [125]	2.283 [58]	0.315 [8]	1.969 [50]	0.394 [10]	1.772 [45]	1.181 [30]	0.787 [20]	0.787 [20]	0.315 x 0.118 [8 x 3]	1.339 [34]	0.512 [13]
CN160DA	6.300 [160]	2.756 [70]	0.374 [9.5]	2.362 [60]	0.394 [10]	3.937 [100]	1.378 [35]	0.984 [25]	0.984 [25]	0.315 x 0.118 [8 x 3]	1.772 [45]	0.630 [16]
CN200DA	7.874 [200]	3.346 [85]	0.472 [12]	2.756 [70]	0.394 [10]	5.315 [135]	1.969 [50]	1.260 [32]	1.260 [32]	0.315 x 0.118 [8 x 3]	2.126 [54]	0.787 [20]
CN250DA	9.843 [250]	3.937 [100]	0.591 [15]	3.543 [90]	0.394 [10]	6.300 [160]	1.969 [50]	1.260 [32]	1.772 [45]	0.394 x 0.157 [10 x 4]	2.756 [70]	0.787 [20]

### INCH [METRIC]

HEAD TYPE	(M x P/LH)	(N <sup>h7</sup> )	(Q x P)	(R)	(S)	(T)	(U <sup>m5</sup> )	(V)	(W x P)	(X <sub>1</sub> )	(X <sub>2</sub> )	(Y)	(Z)
CN100DA	M10 x 1.0	0.472 [12]	M6 x 1.0	0.315 [8]	0.669 [17]	0.197 [5]	0.315 [8]	1.575 [40]	M8 x 1.25	1.811 [46]	2.441 [62]	0.669 [17]	0.795 [20.2]
CN125DA	M12 x 1.5	0.551 [14]	M8 x 1.25	0.315 [8]	0.748 [19]	0.236 [6]	0.394 [10]	1.969 [50]	M10 x 1.5	2.087 [53]	2.992 [76]	0.866 [22]	1.031 [26.2]
CN160DA	M16 x 1.5	0.709 [18]	M8 x 1.25	0.394 [10]	0.984 [25]	0.256 [6.5]	0.472 [12]	2.559 [65]	M12 x 1.75	2.520 [64]	3.937 [100]	1.181 [30]	1.406 [35.7]
CN200DA	M16 x 1.5	0.709 [18]	M8 x 1.25	0.394 [10]	0.984 [25]	0.394 [10]	0.630 [16]	3.346 [85]	M12 x 1.75	4.016 [102]	4.409 [112]	1.575 [40]	1.878 [47.7]
CN250DA	M16 x 1.5	0.709 [18]	M10 x 1.5	0.394 [10]	0.984 [25]	0.472 [12]	0.787 [20]	3.937 [100]	M16 x 2.0	5.000 [127]	5.984 [152]	1.969 [50]	2.346 [59.6]

### Double-Slide Head

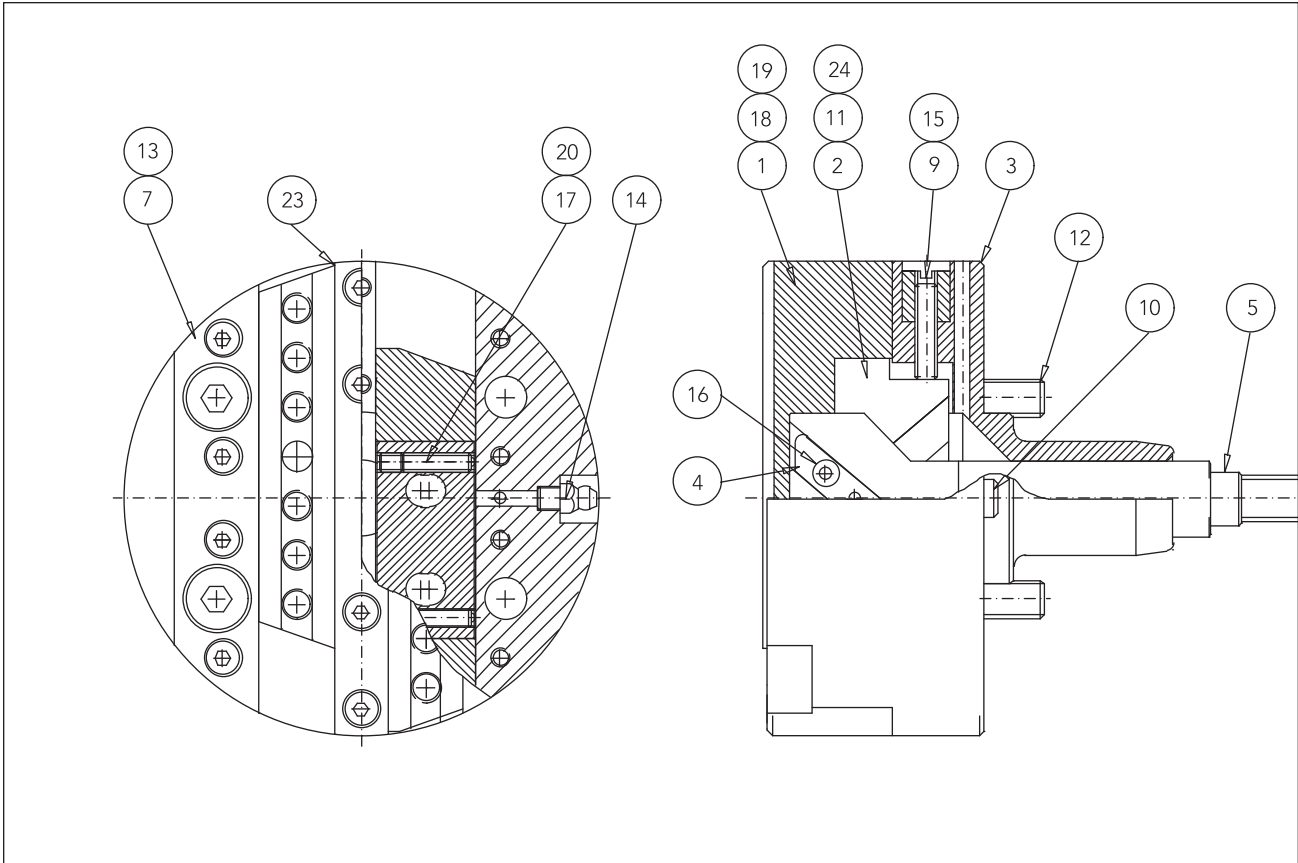

1 Cross-slide	9 Locknut	15 Dog Point Screw	23 Keeper Plate
2 Slide Block	10 Drive Dowel	16 Head Screw	24 Spring Washer
3 Body	11 Lock Screw	17 Spring Plunger	
4 Key	12 Caphead Screw	18 Wiper	
5 Actuator	13 Caphead Screw	19 Location Dowel	
7 Keeper Plate	14 Grease Nipple	20 Set Screw	