



COGSDILL TOOL PRODUCTS, INC.

Flipcut™

For back-spotfacing and back-
or front-chamfering operations —
from one side, in one set-up.

■ **Back-Spotfacing
& Chamfering** TOOLS

Back-Spotfacing

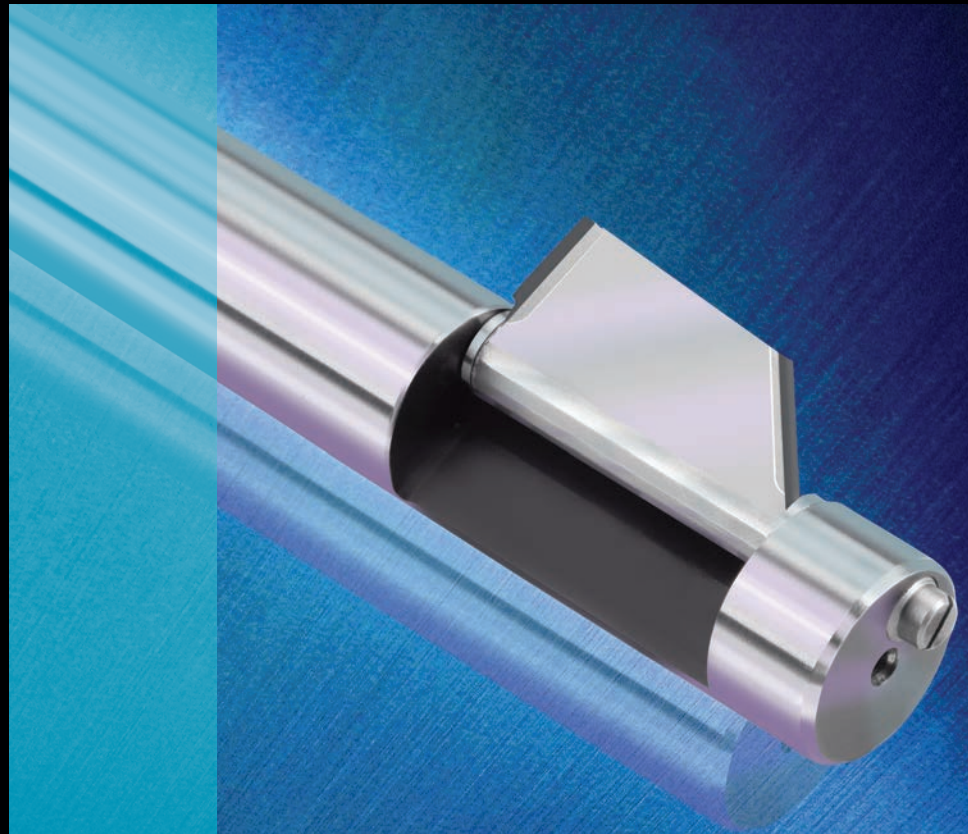

Available from stock for inch hole sizes from .281 to
1.344, and metric hole sizes from 7.00 to 34.00mm.

■ Back-Spotfacing & Chamfering TOOLS

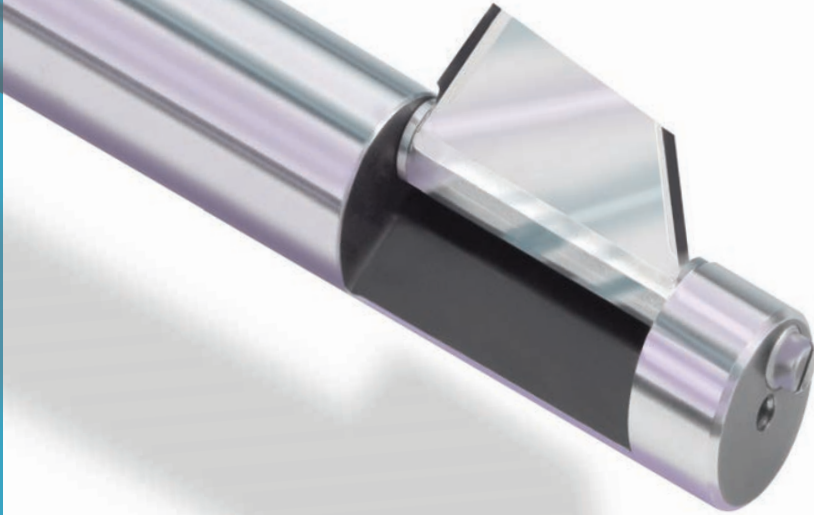

Above: Flipcut™ with cutter extended.

Right: Flipcut™ with cutter retracted.



- Cutter flips open to machine back spotface or back chamfer; flips back to closed position for tool withdrawal. Can also be used for cutting front chamfers. No refixturing or repositioning of workpiece required.
- Right-hand rotation opens cutter; left-hand rotation (spindle reversal) closes cutter.
- Unique tool design: **over-center cam action** initiates positive mechanical closure of the cutter, aided by centrifugal force, for superior tool performance.
- Brazed carbide cutter construction. Cutter is rigidly supported for enhanced accuracy and long tool life.
- Both cutter and arbor are designed for rugged use and long life.
- Shear angle on cutter directs chips away from arbor pocket for controlled chip evacuation.
- Standard tools in the inch program are available in .031 inch increments, with nominal sizes from .281 to 1.344 inches. Standard tools in the metric program are available in 0.5mm increments for hole sizes from 7.00 to 10.00mm, and in 1mm increments in hole sizes from 10.00 to 34.00mm.
- Standard cutter options include a cutter designed for back-spotfacing and front-chamfering operations, and a cutter for back- and front-chamfering operations. Standard program is easily modified to suit other applications.

Flipcut™ design features and options

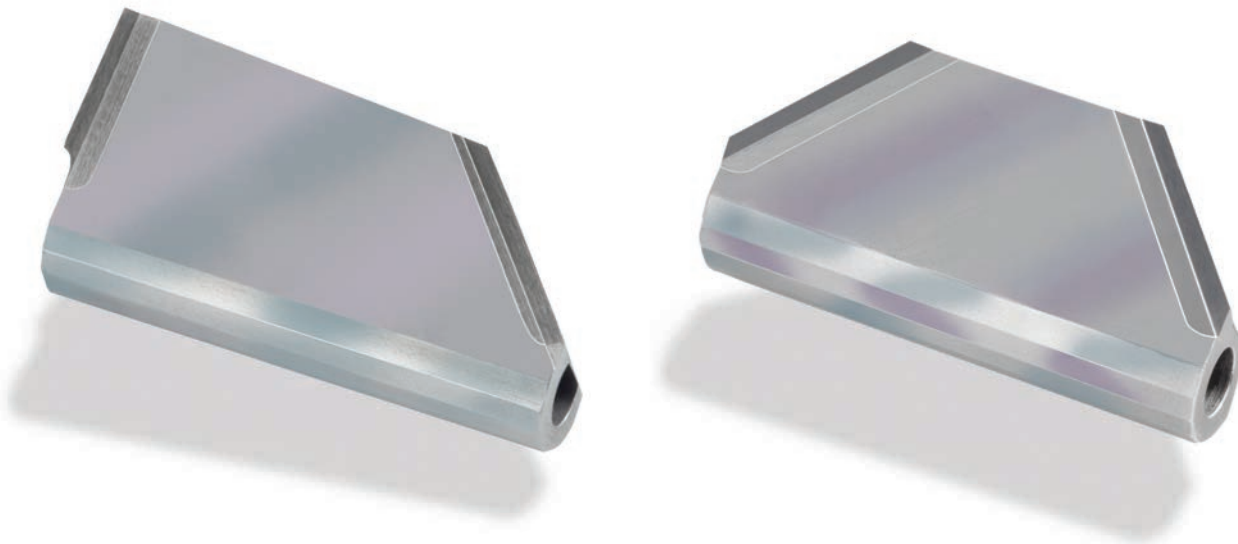

Left: Standard cutter designed for back-spotfacing and front-chamfering.

Right: Standard cutter designed for back- and front-chamfering.

The Flipcut™ tool is designed to perform back-spotfacing or back-chamfering operations **in one set-up**. The cutter extends, with right-hand rotation of the tool, to cut the back spotface or back chamfer. Left-hand spindle rotation initiates positive mechanical closure of the cutter; the closing action is assisted by centrifugal force. When the cutter is fully enclosed within the arbor pocket, the tool can be easily withdrawn from the bore.

The Flipcut™ tool is designed for rugged use on all types of plant equipment and in all kinds of manufacturing environments. Tools for hole sizes from .312 inch and above (inch program) and tools for hole sizes from 8.00mm and above (metric program) have **internal coolant capability**.

Flipcut™ cutters are a brazed carbide design. Steel body absorbs shock. The brazed carbide Flipcut™ cutting edge dissipates heat, for outstanding cutting performance.

Two standard cutters are available from stock:

- Cutter designed for **back-spotfacing and front-chamfering** operations.
- Cutter designed for **back- and front-chamfering** operations.

Other cutter designs are available upon request to suit other applications; contact our sales department and request a quotation.

Specifications

Flipcut™

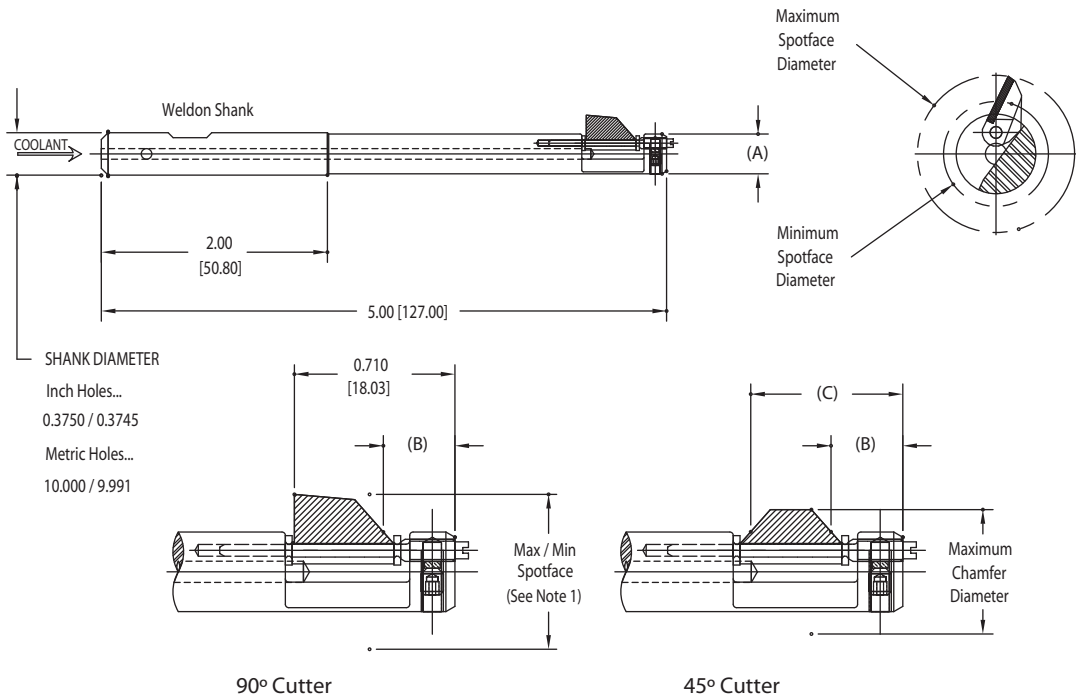

90° Cutter

45° Cutter

* "B" AND "C" DIMENSIONS AT MINIMUM CHAMFER DIAMETER.

HOLE DIAMETER	ARBOR DIA "A"	90° CUTTER		45° CUTTER			
		MAXIMUM SPOTFACE DIAMETER	MINIMUM SPOTFACE DIAMETER	45° CHAMFER CUTTER	MAXIMUM CHAMFER DIAMETER	FRONT CHAMFER "B" REF	REAR CHAMFER "C" REF
Inch program							
0.281*	0.279	0.541	0.414	FW2-45	0.519	0.307	0.683
0.312	0.310	0.634	0.448		0.552	0.306	0.684
0.344	0.342	0.695	0.464		0.568	0.313	0.677
Metric program							
7.00*	6.97	13.36	10.52	FW2-45	13.18	7.75	17.40
7.50*	7.44	13.74	10.52			7.98	17.20
8.00	7.95	16.10	11.37		14.02	7.80	17.35
8.50	8.46	16.48	11.79		14.43	7.82	17.32
9.00	8.94	17.65	11.79			8.05	17.09

Ordering examples

90° BACK SPOTFACING

F C - * * * * - * * * *

SPECIFY HOLE DIAMETER
[CHART SIZES ONLY] See Note 2

IE: INCH 0.281 = **0281**
IE: METRIC 7.00mm = **070M**

SPECIFY SPOTFACE DIAMETER
[CHART SIZES BETWEEN MAX & MIN ONLY] See Note 2

IE: INCH 0.541 = **0541**
IE: METRIC 13.36mm = **1336**

45° CHAMFERING

F C - * * * * - * - **4 5**

SPECIFY HOLE DIAMETER AS ABOVE
[CHART SIZES ONLY] See Note 2

SPECIFY CHAMFER CUTTER SIZE
[CHART SIZE ONLY] See Note 2

IE: FW2-45 = **2**

Note 1

Maximum front chamfer diameter is dimensionally the same as 45° cutter.

Note 2

For all other sizes please contact Cogsdill Tool Products.

For operating guidelines see pages 9-10.

For hardware see page 8.

*Tools for hole diameters from 0.281 to 0.295 in. and from 7.0 to 7.5mm do not have through-coolant capability.

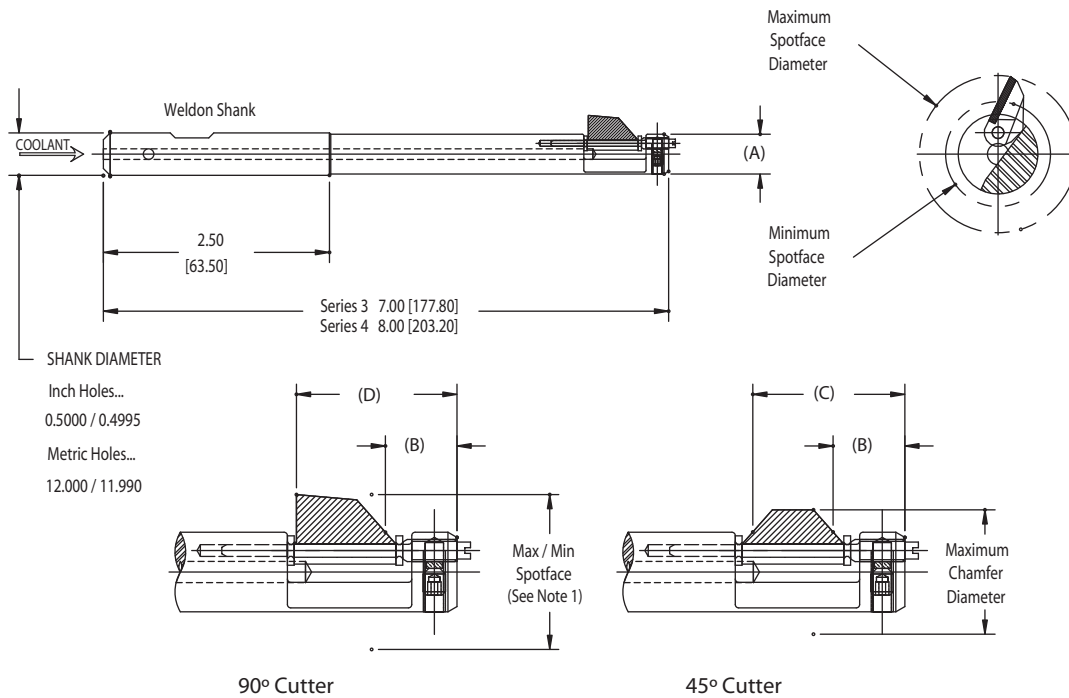

* "B" AND "C" DIMENSIONS AT MINIMUM CHAMFER DIAMETER.

HOLE DIAMETER	ARBOR DIA "A"	90° CUTTER			45° CUTTER			
		MAXIMUM SPOTFACE DIAMETER	MINIMUM SPOTFACE DIAMETER	FRONT SPOTFACE "D" REF	45° CHAMFER CUTTER	MAXIMUM CHAMFER DIAMETER	FRONT CHAMFER "B" REF	REAR CHAMFER "C" REF
Inch program								
0.375	0.372	0.750	0.542	0.930	FW3-45	0.711	0.345	0.900
0.406	0.403	0.835	0.572	0.930		0.741	0.345	0.900
0.438	0.435	0.866	0.572	0.930			0.359	0.886
0.469	0.466	0.960	0.693	1.095	FW4-45	0.887	0.379	1.081
0.500	0.497	0.989	0.693	1.095			0.393	1.067
0.531	0.528	1.111	0.743	1.095		0.937	0.407	1.053
0.562	0.559	1.141	0.743	1.095			0.421	1.040
Metric program								
9.50	9.42	19.05	13.77	23.62	FW3-45	18.06	8.73	22.89
10.00	9.93	19.81	14.53	23.62		18.82	8.64	22.99
11.00	10.92	21.21	14.53	23.62			9.07	22.56
12.00	11.91	24.38	17.60	27.81	FW4-45	22.53	9.68	27.41
13.00	12.93	25.12	17.60	27.81			10.11	26.97
14.00	13.92	28.22	18.87	27.81		23.80	10.57	26.52

Ordering examples

90° BACK SPOTFACING **FC** - * * * * - * * * *

SPECIFY HOLE DIAMETER [CHART SIZES ONLY] See Note 2

IE: INCH 0.375 = **0375**
IE: METRIC 9.50mm = **095M**

SPECIFY SPOTFACE DIAMETER [CHART SIZES BETWEEN MAX & MIN ONLY] See Note 2

IE: INCH 0.694 = **0694**
IE: METRIC 17.62mm = **1762**

Note 1 Maximum front chamfer diameter is dimensionally the same as 45° cutter.

Note 2 For all other sizes please contact Cogsdill Tool Products.

45° CHAMFERING **FC** - * * * * - * - **4 5**

SPECIFY HOLE DIAMETER AS ABOVE [CHART SIZES ONLY] See Note 2

SPECIFY CHAMFER CUTTER SIZE [CHART SIZES ONLY] See Note 2

IE: FW3-45 = **3**

For operating guidelines see pages 9-10.
For hardware see page 8.

Specifications

Flipcut™

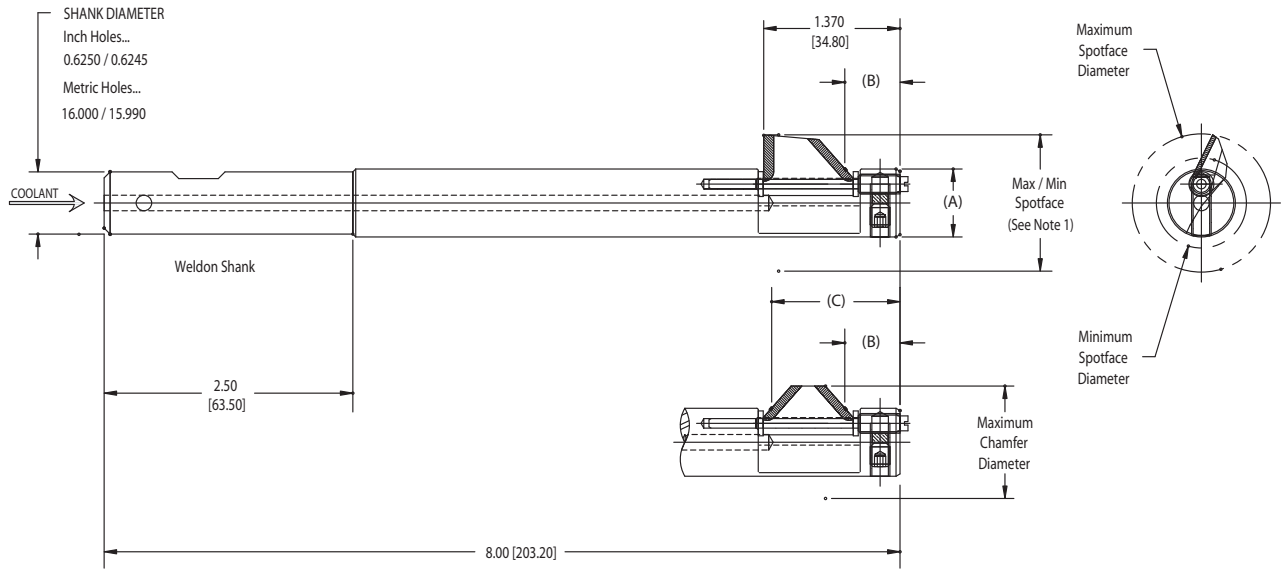

* "B" AND "C" DIMENSIONS AT MINIMUM CHAMFER DIAMETER.

HOLE DIAMETER	ARBOR DIA "A"	90° CUTTER		45° CUTTER			
		MAXIMUM SPOTFACE DIAMETER	MINIMUM SPOTFACE DIAMETER	45° CHAMFER CUTTER	MAXIMUM CHAMFER DIAMETER	FRONT CHAMFER "B" REF	REAR CHAMFER "C" REF
Inch program							
0.594	0.589	1.205	0.855	FW5-45	1.112	0.536	1.309
0.625	0.620	1.237	0.855			0.550	1.296
0.656	0.651	1.359	0.905		1.161	0.541	1.304
0.688	0.683	1.390	0.905			0.555	1.290
Metric program							
15.00	14.88	30.00	21.72	FW5-45	28.24	13.56	33.30
16.00	15.88	31.42	21.72			14.02	32.84
17.00	16.87	34.51	22.99		29.49	13.89	32.97

Ordering examples

90° BACK SPOTFACING **F C** - * * * * - * * * *

SPECIFY HOLE DIAMETER
[CHART SIZES ONLY] See Note 2

IE: INCH 0.594 = **0594**
IE: METRIC 15.00mm = **150M**

SPECIFY SPOTFACE DIAMETER
[CHART SIZES BETWEEN MAX & MIN ONLY] See Note 2

IE: INCH 1.205 = **1205**
IE: METRIC 30.00mm = **3000**

45° CHAMFERING **F C** - * * * * - * - **4 5**

SPECIFY HOLE DIAMETER AS ABOVE
[CHART SIZES ONLY] See Note 2

SPECIFY CHAMFER CUTTER SIZE
[CHART SIZE ONLY] See Note 2

IE: FW5-45 = **5**

Note 1 Maximum front chamfer diameter is dimensionally the same as 45° cutter.

Note 2 For all other sizes please contact Cogsdill Tool Products.

For operating guidelines see pages 9-10.

For hardware see page 8.

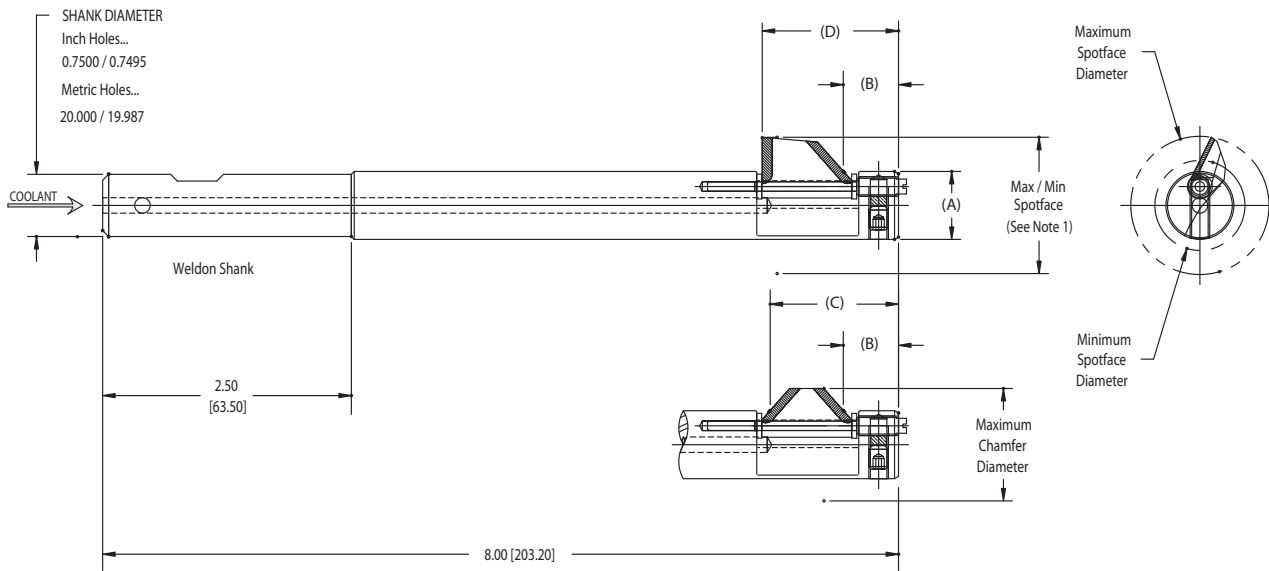

* "B" AND "C" DIMENSIONS AT MINIMUM CHAMFER DIAMETER.

HOLE DIAMETER	ARBOR DIA "A"	90° CUTTER		45° CUTTER				
		MAXIMUM SPOTFACE DIAMETER	MINIMUM SPOTFACE DIAMETER	45° CHAMFER CUTTER	MAXIMUM CHAMFER DIAMETER	FRONT CHAMFER "B" REF	REAR CHAMFER "C" REF	FRONT SPOTFACE "D" REF

Inch program

0.719	0.714	1.505	1.059	FW6-45	1.359	0.542	1.448	1.515
0.750	0.745	1.535	1.059			0.556	1.434	
0.781	0.776	1.564	1.059			0.570	1.420	
0.812	0.807	1.609	1.241	FW7-45	1.603	0.688	1.980	2.079
0.844	0.839	1.640	1.241			0.703	1.966	
0.875	0.870	1.782	1.301			1.662	0.689	
0.906	0.901	1.812	1.301	0.703	1.965			
0.938	0.933	1.842	1.301	0.717	1.951			
0.969	0.964	1.872	1.301	0.731	1.938			

Metric program

18.00	17.88	37.44	26.90	FW6-45	34.52	13.67	36.88	38.48	
19.00	18.87	38.99	26.90			14.12	36.42		
20.00	19.86	39.72	26.90			14.55	36.02		
21.00	20.88	40.86	31.52	FW7-45	40.71	17.63	50.14	52.81	
22.00	21.87	43.18	33.05			42.21	17.40		50.37
23.00	22.89	46.78	33.05				17.86		49.91
24.00	23.88	46.78	33.05				18.29		49.48
25.00	24.87	47.54	33.05				18.72		49.05

Ordering examples

90° BACK SPOTFACING

FC - * * * * - * * * *

SPECIFY HOLE DIAMETER [CHART SIZES ONLY] See Note 2

IE: INCH 0.719 = **0719**
IE: METRIC 18.00mm = **180M**

SPECIFY SPOTFACE DIAMETER [CHART SIZES BETWEEN MAX & MIN ONLY] See Note 2

IE: INCH 1.505 = **1505**
IE: METRIC 37.44mm = **3744**

45° CHAMFERING

FC - * * * * - * - **4 5**

SPECIFY HOLE DIAMETER AS ABOVE [CHART SIZES ONLY] See Note 2

SPECIFY CHAMFER CUTTER SIZE [CHART SIZE ONLY] See Note 2

IE: FW6-45 = **6**

Note 1 Maximum front chamfer diameter is dimensionally the same as 45° cutter.

Note 2 For all other sizes please contact Cogsdill Tool Products.

For operating guidelines see pages 9-10.

For hardware see page 8.

Specifications

Flipcut™

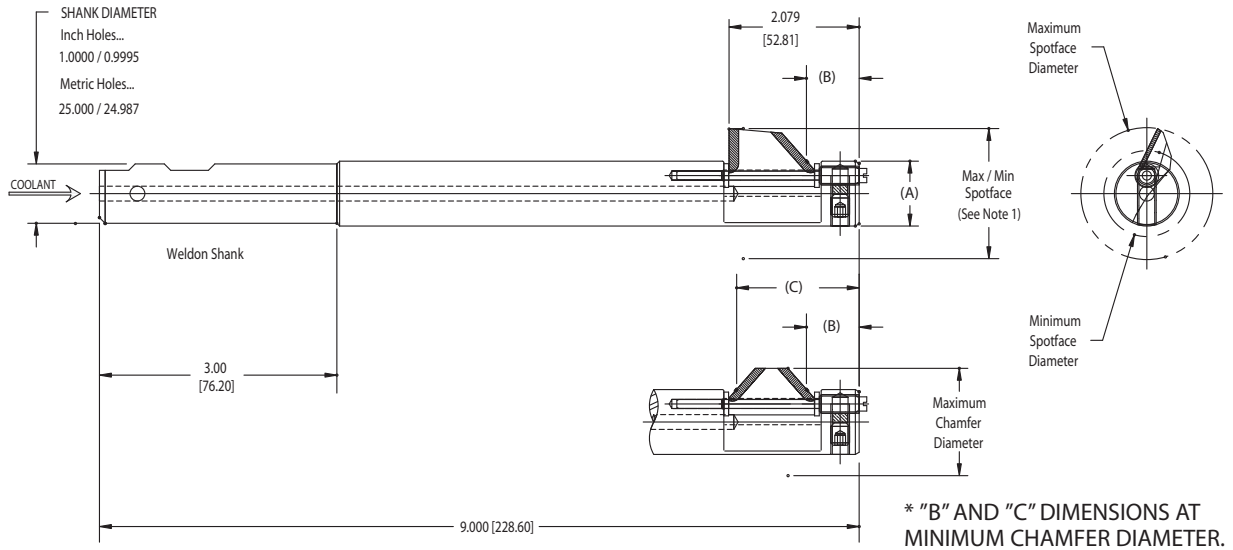

HOLE DIAMETER	ARBOR DIA "A"	90° CUTTER		45° CUTTER			
		MAXIMUM SPOTFACE DIAMETER	MINIMUM SPOTFACE DIAMETER	45° CHAMFER CUTTER	MAXIMUM CHAMFER DIAMETER	FRONT CHAMFER "B" REF	REAR CHAMFER "C" REF

Inch program

1.000	0.993	2.142	1.431	FW7-45	1.792	0.687	1.981
1.031	1.024	2.172	1.431			0.700	1.968
1.062	1.055	2.201	1.431			0.714	1.954
1.093	1.086	2.231	1.431		0.728	1.940	
1.125	1.118	2.444	1.531		1.890	0.698	1.970
1.156	1.149	2.474	1.531			0.712	1.956
1.187	1.180	2.503	1.531			0.725	1.943
1.219	1.212	2.534	1.531		0.740	1.928	
1.250	1.243	2.662	1.661		2.021	0.696	1.972
1.281	1.274		1.661			0.709	1.959
1.312	1.305		1.661			0.723	1.945
1.344	1.337		1.661			0.737	1.931

Metric program

26.00	25.83	54.40	36.35	FW7-45	45.51	17.70	50.06
26.50	26.31	55.16	36.35			17.93	49.83
27.00	26.82	55.90	36.35			18.16	49.61
28.00	27.81	59.15	38.89		48.01	17.48	50.29
29.00	28.83	62.07	38.89			17.91	49.86
30.00	29.82	62.83	38.89			18.36	49.40
31.00	30.81	64.36	38.89		18.80	48.97	
32.00	31.83	67.61	42.19		51.33	17.78	49.99
33.00	32.82		42.19			18.14	49.63
34.00	33.83		42.19			18.67	49.10

Ordering examples

90° BACK SPOTFACING **F C** - * * * * - * * * *

SPECIFY HOLE DIAMETER [CHART SIZES ONLY] See Note 2

IE: INCH 1.000 = **1000**
IE: METRIC 26.00mm = **260M**

SPECIFY SPOTFACE DIAMETER [CHART SIZES BETWEEN MAX & MIN ONLY] See Note 2

IE: INCH 2.142 = **2142**
IE: METRIC 54.40mm = **5440**

Note 1 Maximum front chamfer diameter is dimensionally the same as 45° cutter.

Note 2 For all other sizes please contact Cogsdill Tool Products.

45° CHAMFERING **F C** - * * * * - * - **4 5**

SPECIFY HOLE DIAMETER AS ABOVE [CHART SIZES ONLY] See Note 2

SPECIFY CHAMFER CUTTER SIZE [CHART SIZE ONLY] See Note 2

IE: FW7-45 = **7**

For operating guidelines see pages 9-10.

For hardware see page 8.

Flipcut™ Hardware

HOLE SIZE IN (mm)	RETAINING SCREW	LOCKING SCREW*	PAD	SPACER
0.281 - 0.344 (7.0 - 9.0)	FRS-2	M2.5x3LG	FP-2	FS-2
0.375 - 0.438 (9.5 - 11.0)	FRS-3	M3x4LG	FP-3	FS-3
0.469 - 0.562 (12.0 - 14.0)	FRS-4	M4x4LG	FP-4	FS-4
0.594 - 0.688 (15.0 - 17.0)	FRS-5	M5x6LG	FP-5	FS-5
0.719 - 0.781 (18.0 - 20.0)	FRS-6	M6x8LG	FP-6	FS-6
0.812 - 1.344 (21.0 - 34.0)	FRS-7	M8x6LG	FP-7	FS-7

*Standard metric flat point socket set screw

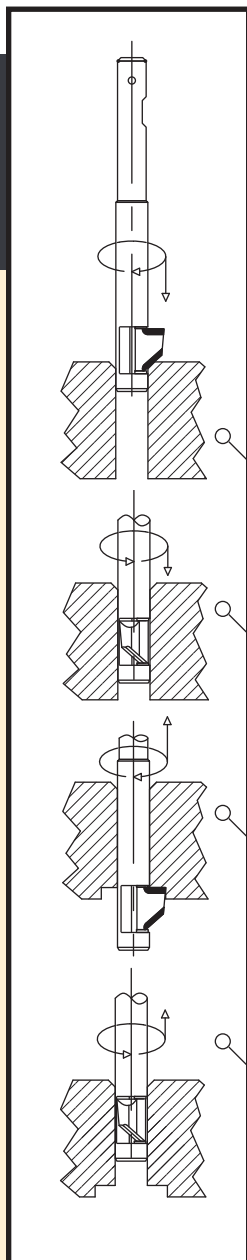

Operation

Flipcut™

How it works

NOTE: The tool operation sequence shown depicts the tool with a standard cutter machining a **back spotface** and a **front chamfer** in one set-up. Tool operation is similar when using a standard cutter to machine **back and front chamfers**.

- 1.** The front chamfer is machined upon entry into the bore, using right hand rotation (clockwise) of the machine spindle at the appropriate speed (refer to chart on page 10), and .002 IPR (0.05mm/rev).
- 2.** Left hand rotation (counterclockwise) at a maximum of .008 IPR (0.20mm/rev) will effect mechanical closure of the cutter (aided by centrifugal force) so that the tool can feed through the bore.
- 3.** The back spotface is machined, using right hand rotation (clockwise) at the appropriate speed (refer to chart on page 10), and .002 IPR (0.05 mm/rev).
- 4.** Left hand rotation (counterclockwise) at a maximum of .008 IPR (0.20mm/rev) will close the cutter so that the tool can be retracted from the bore.

NOTE: Coolant should be shut off when retracting cutter to ensure cutter closure.

Operating guidelines

- Always ensure that the cutter rotates freely in the arbor and that no end float can be detected. This can be accomplished by adjusting the retaining screw (see photo below) until the cutter binds, then backing off approximately 5 degrees. Using the locking screw, lock the retaining screw at this position.
- Ensure that the spindle speed is sufficient to allow the cutter to open.
- After the cut has been completed, and the tool withdrawn from the hole, make sure that enough coolant is supplied to the end of the tool to flush away any remaining chips that might prevent the tool from opening and closing freely in subsequent operations.
- NEVER run the tool without coolant.
- The tool cannot be used in a lathe with a static turret, since it must be rotated in order for the cutter to extend and retract. The tool may only be used in a live spindle in lathe applications.
- After completing the cut, always feed the tool off the part before stopping the spindle and reversing for withdrawal.

NOTE: In some cases, the cutter may not close fully into the arbor when the spindle is reversed. This should be considered as normal; the cutter will close fully as it passes back through the bore on the return stroke. The retraction feed should be the same as the machining feed until the cutter is fully closed and sheltered by the arbor; then rapid feed may be introduced.

NOTE: Coolant should be shut off when retracting cutter to ensure cutter closure.

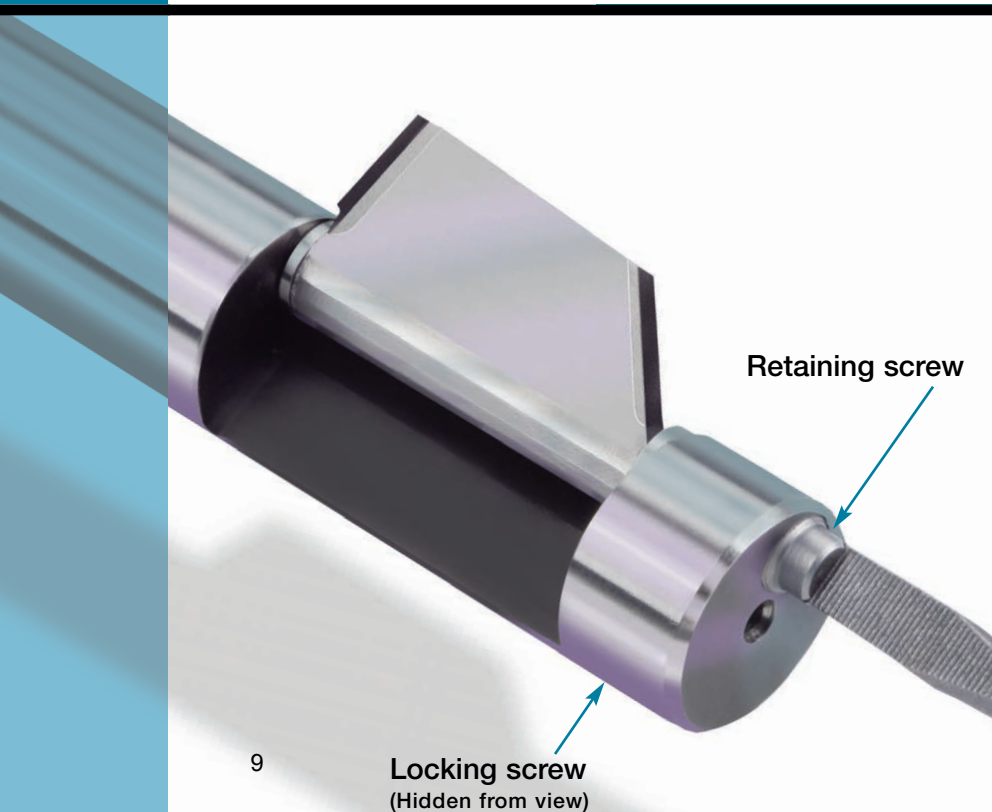

To ensure that the cutter rotates freely in the arbor, with no end float, adjust the retaining screw until the cutter binds, then back off approximately 5 degrees. Use the locking screw to lock the retaining screw at this position.

Speeds and feeds

HOLE SIZE IN (mm)	SPINDLE SPEED	FEED RATE*
0.344 (8.00)	600 rpm	0.002 in/rev (0.05mm/rev)
0.689 (17.50)	550 rpm	
0.813 (21.0)	350 rpm	
1.000 (25.50)	275 rpm	
1.344 (34.00)	250 rpm	

NOTE: For horizontal applications, the tool should be run at two times the recommended speed.

*Feed rate is the maximum value. When feeding the tool through the hole, prior to the back-spotfacing operation, use reverse spindle rotation and .008 IPR (0.20 mm/rev) maximum feed rate.

Coolant

Coolant flow is necessary and should be directed to the arbor pocket and cutting edge to lubricate and flush chips away. Straight cutting oil, water soluble, or synthetic coolant can be used. The coolant should be clean and have good lubricity.

NOTE: Coolant should be shut off when retracting cutter to ensure cutter closure.

Cycle

The tool must be able to rotate in both clockwise and counterclockwise directions. The tool should run in counterclockwise rotation at the recommended speed and should feed in and out of the bore at .008 IPR (0.20 mm/rev) maximum.

The cutter should be clear of the part when changing the direction of rotation.

Maintenance

The Flipcut™ tool should be inspected periodically for cutter axial movement, and the retaining screw adjusted accordingly. The tool should also be inspected periodically for wear, and the cutter changed or sharpened when necessary. The retaining screw should be inspected closely for wear or damage and replaced if necessary.

Cutter installation and setting

When the cutter is worn, loosen the locking screw (refer to the drawing below). Remove both locking screw and pad. Loosen the retaining screw and remove the worn cutter. The cutter may be reground (see page 12, “Cutter Regrinding”) or replaced.

Clean all components thoroughly and apply light lubricating oil to each part for assembly.

Referring to diagram below...

- 1| Place and hold (2) **spacers** at the front and rear barrel diameter of the **cutter** while assembling into the slot on the arbor.
- 2| With **cutter** and **spacers** in place, insert **retaining screw** through the threaded hole in the end of the **arbor** and then through the first **spacer**, the hole through the **cutter**, the second **spacer**, and into the hole at the furthest end of the **arbor** slot.
- 3| When all components are aligned and positioned correctly thread the **retaining screw** into the threaded hole in the end of the **arbor** until it makes contact with the **spacer** and the **cutter** goes tight. The **cutter** should **NOT** pivot freely at this point.
- 4| Assemble the **pad** and **locking screw** into the threaded hole in the front outside diameter of the **arbor**.
- 5| Tighten the **locking screw** lightly.
- 6| Unscrew the **retaining screw** very slightly until the **cutter** freely hinges between the fully open and fully closed positions.
- 7| Check that the axial movement in the **cutter** is at the minimum but still allowing free hinging movement of the **cutter**. Measured axial gap should be 0.005 to 0.010 inches, (0.013 to 0.025mm).
- 8| When satisfied that the cutter assembly is correct, tighten the **locking screw**.

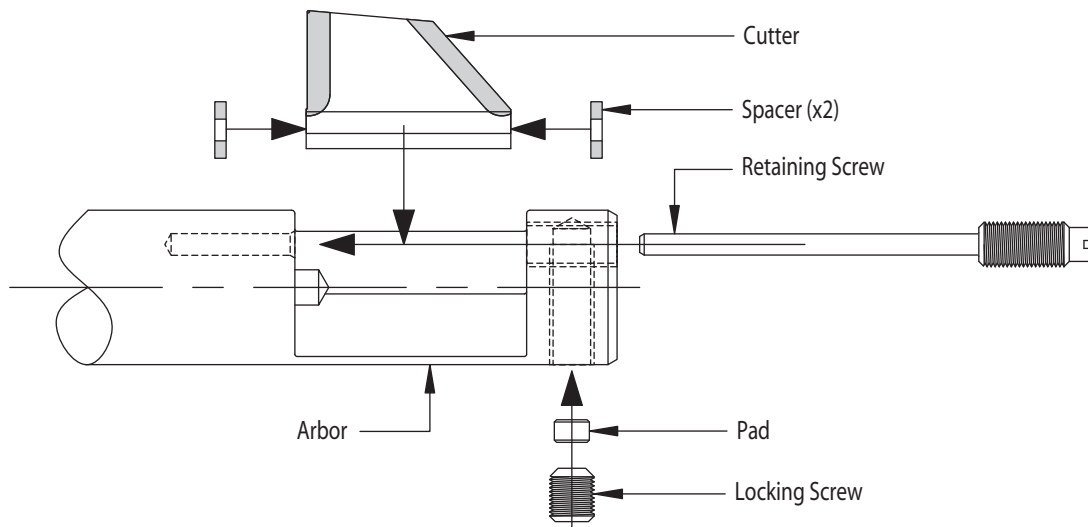

Cutter regrinding

Regrind procedure for standard cutter for machining back spotface and front chamfer

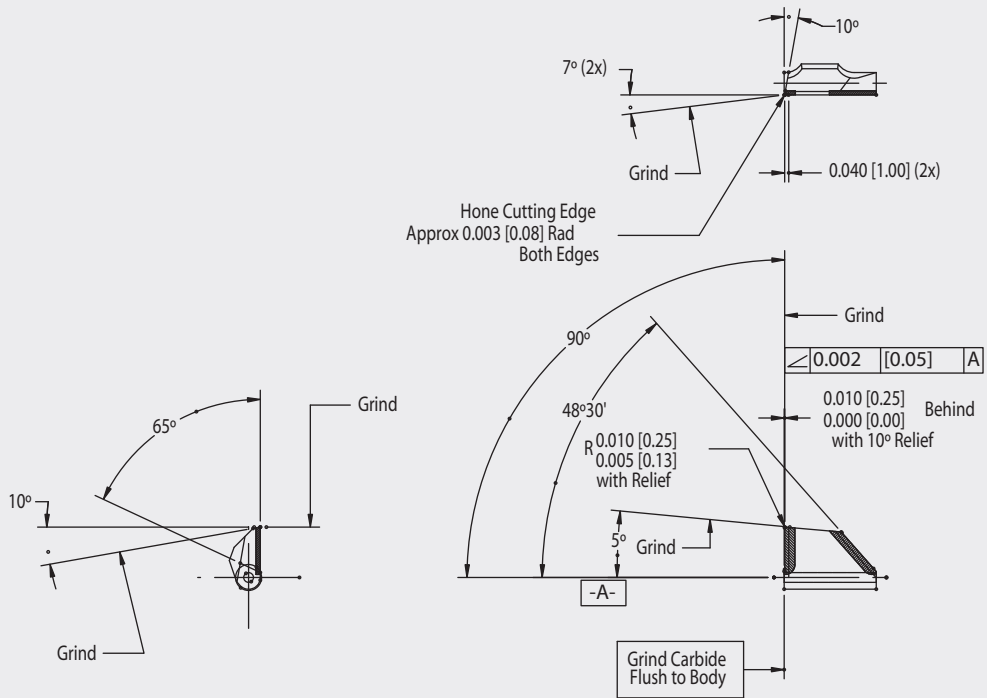

Inch [Metric]

Regrind procedure for standard cutter for machining back and front chamfers

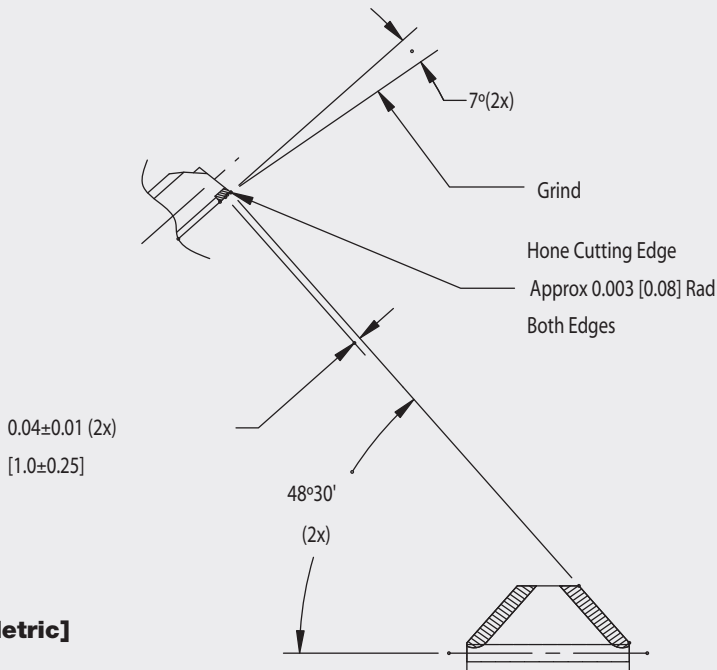

Inch [Metric]

Ordering

To order a Flipcut™ tool, determine your tool number as shown under each tool specification chart (pages 3-7). The tools shown in the charts are standard, and available on a quick delivery basis.

Tools other than shown in the specification charts are special (e.g., intermediate sizes, longer or shorter work lengths, or special cutter geometries). Please contact Cogsdill Tool Products and request a quotation.

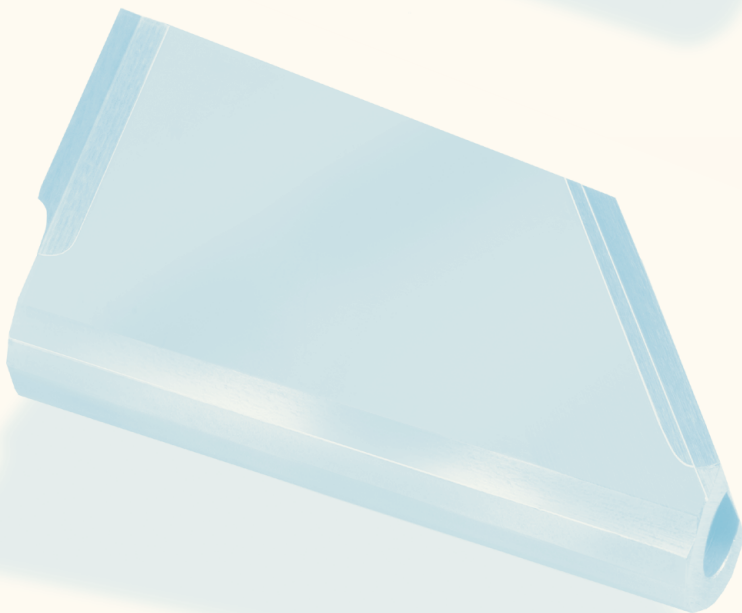
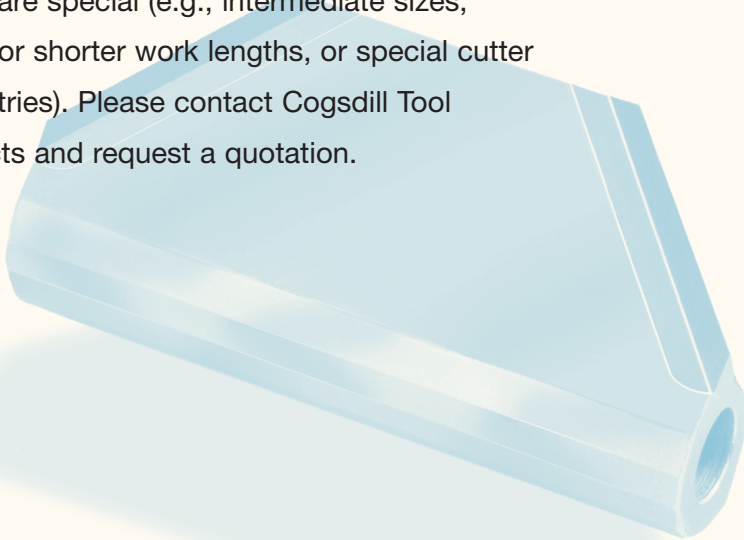



COGSDILL TOOL PRODUCTS, INC.

visit our web site at

www.cogsdill.com

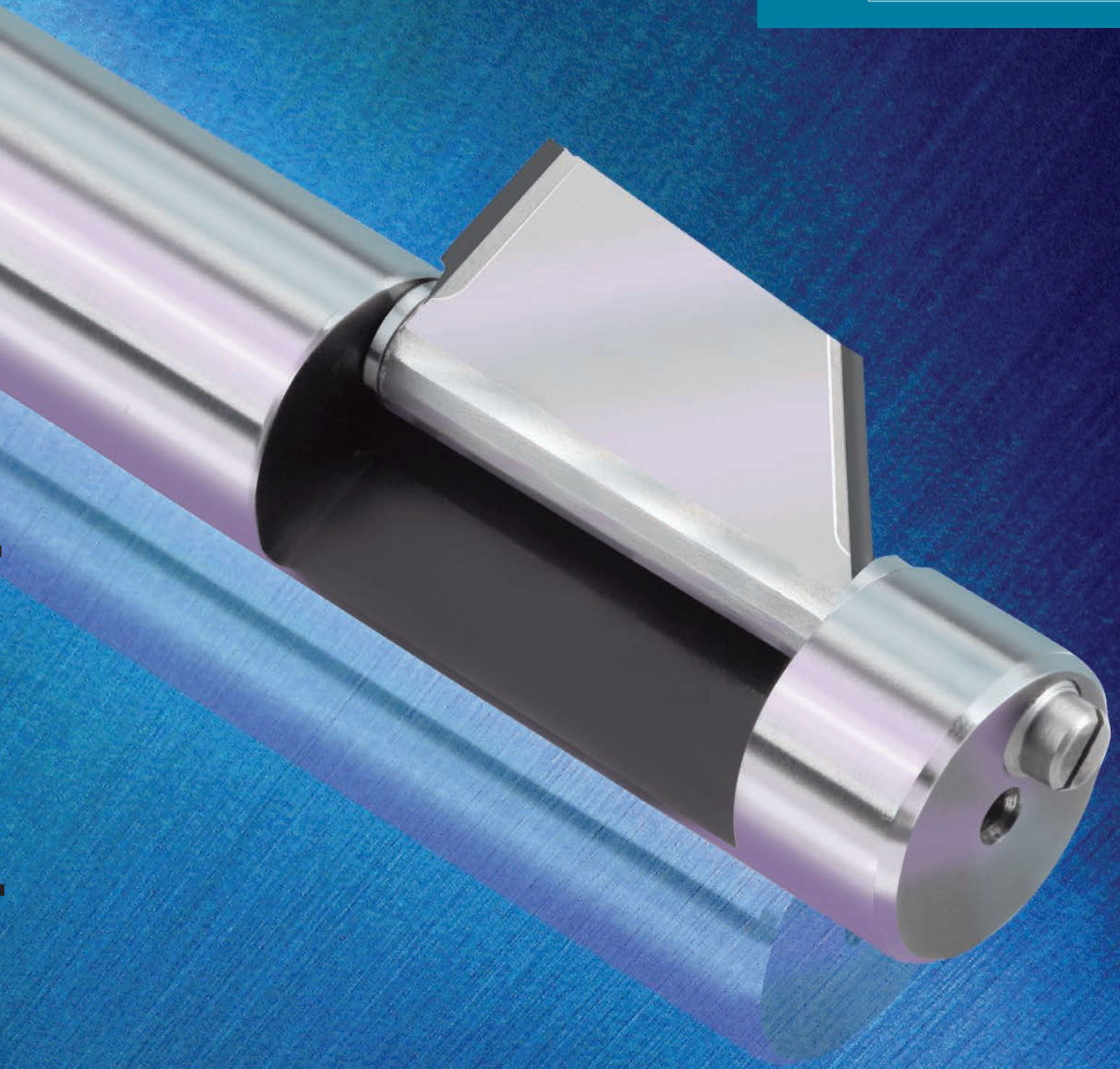

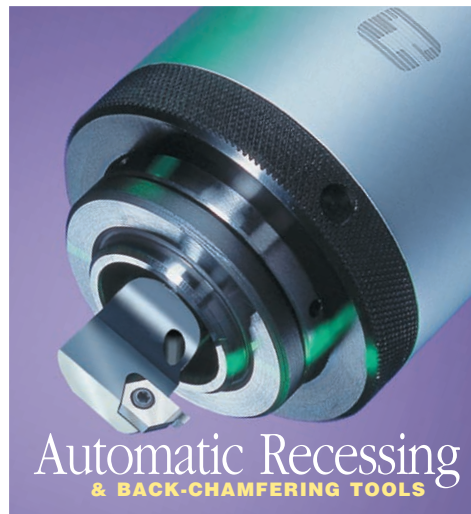
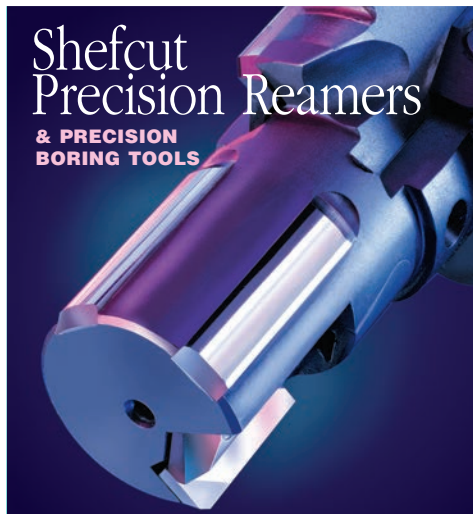
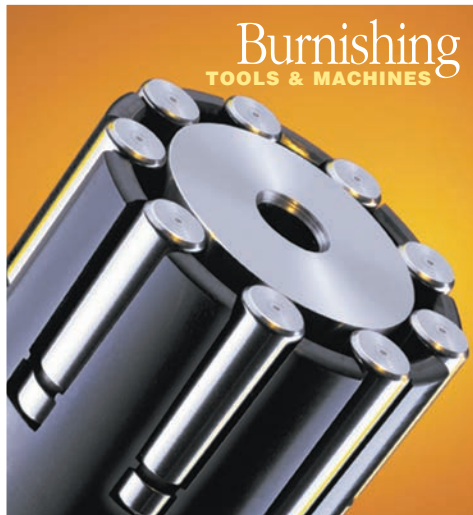

COGSDILL TOOL PRODUCTS, INC.

Mailing Address

P.O. Box 7007
Camden, SC USA 29021-7007
Ph. (803) 438-4000
Fax (803) 438-5263
www.cogsdill.com
cogsdill@cogsdill.com

Shipping Address

1001 Guion Drive
Lugoff, SC 29078

COGSDILL-NUNEATON LIMITED

St George's Way
Bermuda Industrial Estate
Nuneaton, Warwickshire, CV10 7JS, UK
Ph. +44 (0) 2476 383792
Fax +44 (0) 2476 344433
www.cogsdill.co.uk
sales@cogsdill.co.uk

FOR ADDITIONAL INFORMATION



Visit us online

www.cogsdill.com

BROCHURE NO. 043 U.S. 12-14