

Internal Roll-a-Finish® tools

SR Series

Our premier line of internal Roll-a-Finish® tools, designed to suit all applications. Ideal for applications where tool length is restricted by tool changers, turrets, etc.



Offered in *three styles:*

- Through-hole style with no-helix cage (machine-feeding)
- Through-hole style with helix cage (self-feeding)
- Bottoming-style for blind hole, with no-helix cage (machine-feeding)



... with up to *four work lengths:*

- Two inch (SR)
- Four inch (SR-4)
- Six inch (SR-6)
- Eight inch (SR-8)

... and *available from stock:*

- for hole sizes from .187 to 2.500 inches (4.75 to 63.5mm).
- Tools are adjustable in increments of .0001 inch (.002mm).

Standard tool specifications

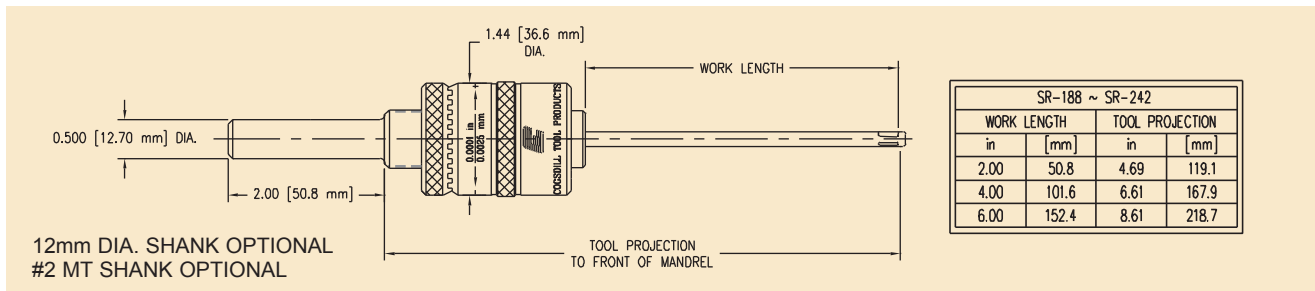

“SR” SERIES ROLL-A-FINISH® TOOLS 3/16 TO 1/4 IN. (4.76 TO 6.35mm)

DIAMETER RANGE		TOOL NUMBER		
INCHES	MM	THRU-HOLE (NO HELIX)	THRU-HOLE (HELIX)	BOTTOMING (NO HELIX)
.187-.195	4.75-4.95	SR-188	SRH-188	_____
.194-.202	4.93-5.13	SR-195	SRH-195	_____
.202-.210	5.13-5.33	SR-203	SRH-203	_____
.210-.218	5.33-5.54	SR-211	SRH-211	_____
.218-.226	5.54-5.74	SR-219	SRH-219	_____
.225-.233	5.72-5.92	SR-226	SRH-226	_____
.233-.241	5.92-6.12	SR-234	SRH-234	_____
.241-.249	6.12-6.32	SR-242	SRH-242	_____

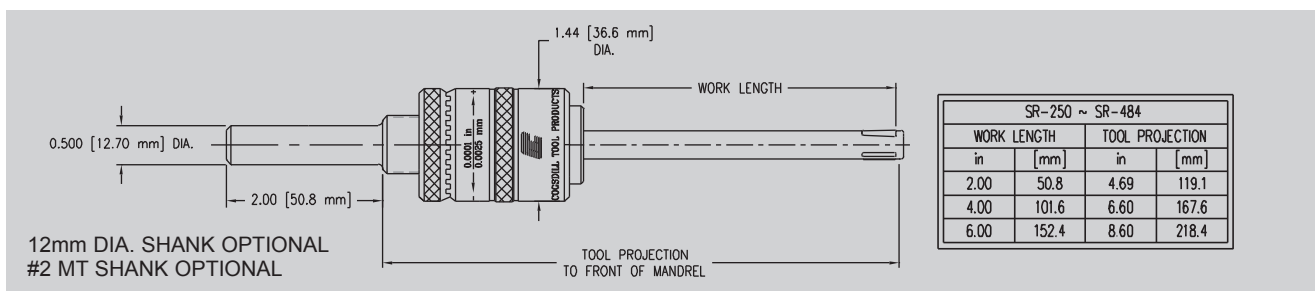

“SR” SERIES ROLL-A-FINISH® TOOLS 1/4 TO 1/2 IN. (6.35 TO 12.70mm)

DIAMETER RANGE		TOOL NUMBER		
INCHES	MM	THRU-HOLE (NO HELIX)	THRU-HOLE (HELIX)	BOTTOMING (NO HELIX)
.246-.267	6.25-6.78	SR-250	SRH-250	SRB-250
.262-.283	6.65-7.19	SR-266	SRH-266	SRB-266
.277-.298	7.04-7.57	SR-281	SRH-281	SRB-281
.293-.314	7.44-7.98	SR-297	SRH-297	SRB-297
.308-.329	7.82-8.36	SR-312	SRH-312	SRB-312
.324-.345	8.23-8.76	SR-328	SRH-328	SRB-328
.340-.361	8.64-9.17	SR-344	SRH-344	SRB-344
.355-.376	9.02-9.55	SR-359	SRH-359	SRB-359
.371-.392	9.42-9.96	SR-375	SRH-375	SRB-375
.387-.408	9.83-10.36	SR-391	SRH-391	SRB-391
.402-.423	10.21-10.74	SR-406	SRH-406	SRB-406
.418-.439	10.62-11.15	SR-422	SRH-422	SRB-422
.434-.455	11.02-11.56	SR-438	SRH-438	SRB-438
.449-.470	11.40-11.94	SR-453	SRH-453	SRB-453
.465-.486	11.81-12.34	SR-469	SRH-469	SRB-469
.480-.501	12.19-12.73	SR-484	SRH-484	SRB-484

Shanks other than shown above are available upon request.

Standard tool specifications

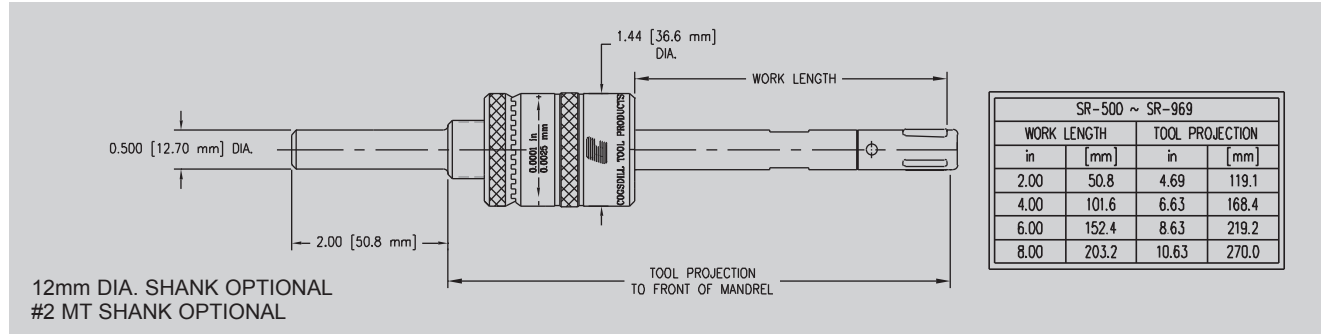

"SR" SERIES ROLL-A-FINISH® TOOLS 1/2 TO 1 IN. (12.70 TO 25.40 mm)

DIAMETER RANGE		TOOL NUMBER		
INCHES	MM	THRU-HOLE (NO HELIX)	THRU-HOLE (HELIX)	BOTTOMING (NO HELIX)
.496-.537	12.60-13.64	SR-500	SRH-500	SRB-500
.527-.568	13.39-14.43	SR-531	SRH-531	SRB-531
.558-.599	14.17-15.21	SR-562	SRH-562	SRB-562
.590-.631	14.99-16.03	SR-594	SRH-594	SRB-594
.621-.662	15.77-16.81	SR-625	SRH-625	SRB-625
.652-.693	16.56-17.60	SR-656	SRH-656	SRB-656
.684-.725	17.37-18.42	SR-688	SRH-688	SRB-688
.715-.756	18.16-19.20	SR-719	SRH-719	SRB-719
.746-.787	18.95-19.99	SR-750	SRH-750	SRB-750
.777-.818	19.74-20.78	SR-781	SRH-781	SRB-781
.808-.849	20.52-21.56	SR-812	SRH-812	SRB-812
.840-.881	21.34-22.38	SR-844	SRH-844	SRB-844
.871-.912	22.12-23.16	SR-875	SRH-875	SRB-875
.902-.943	22.91-23.95	SR-906	SRH-906	SRB-906
.934-.975	23.72-24.77	SR-938	SRH-938	SRB-938
.965-1.006	24.51-25.55	SR-969	SRH-969	SRB-969

Shanks other than shown above are available upon request.

Standard tool specifications

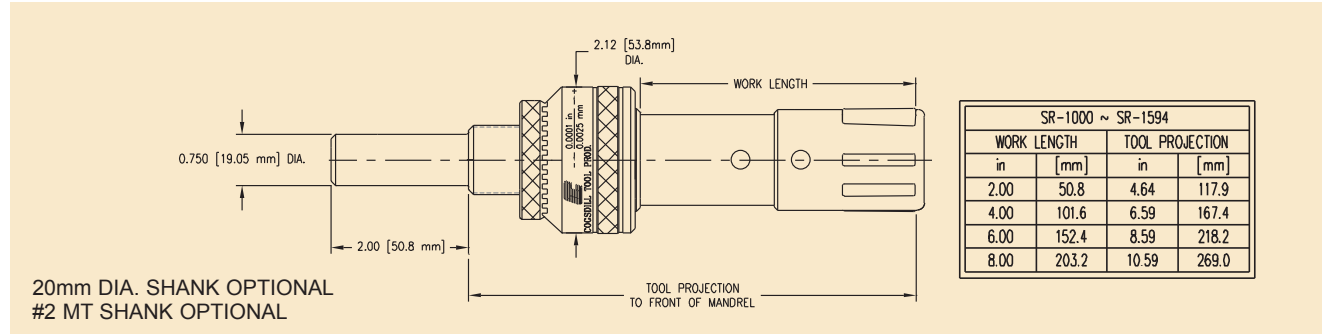

“SR” SERIES ROLL-A-FINISH® TOOLS 1 TO 1-5/8 IN. (25.4 TO 41.28mm)

DIAMETER RANGE		TOOL NUMBER		
INCHES	MM	THRU-HOLE (NO HELIX)	THRU-HOLE (HELIX)	BOTTOMING (NO HELIX)
.996-1.037	25.30-26.34	SR-1000	SRH-1000	SRB-1000
1.027-1.068	26.09-27.13	SR-1031	SRH-1031	SRB-1031
1.058-1.099	26.87-27.91	SR-1062	SRH-1062	SRB-1062
1.090-1.131	27.69-28.73	SR-1094	SRH-1094	SRB-1094
1.121-1.162	28.47-29.51	SR-1125	SRH-1125	SRB-1125
1.152-1.193	29.26-30.30	SR-1156	SRH-1156	SRB-1156
1.184-1.225	30.07-31.12	SR-1188	SRH-1188	SRB-1188
1.215-1.256	30.86-31.90	SR-1219	SRH-1219	SRB-1219
1.246-1.287	31.65-32.69	SR-1250	SRH-1250	SRB-1250
1.277-1.318	32.44-33.48	SR-1281	SRH-1281	SRB-1281
1.308-1.349	33.22-34.26	SR-1312	SRH-1312	SRB-1312
1.340-1.381	34.04-35.08	SR-1344	SRH-1344	SRB-1344
1.371-1.412	34.82-35.86	SR-1375	SRH-1375	SRB-1375
1.402-1.443	35.61-36.65	SR-1406	SRH-1406	SRB-1406
1.434-1.475	36.42-37.47	SR-1438	SRH-1438	SRB-1438
1.465-1.506	37.21-38.25	SR-1469	SRH-1469	SRB-1469
1.496-1.537	38.00-39.04	SR-1500	SRH-1500	SRB-1500
1.527-1.568	38.79-39.83	SR-1531	SRH-1531	SRB-1531
1.558-1.599	39.57-40.61	SR-1562	SRH-1562	SRB-1562
1.590-1.631	40.39-41.43	SR-1594	SRH-1594	SRB-1594

Shanks other than shown above are available upon request.

Standard Tool specifications

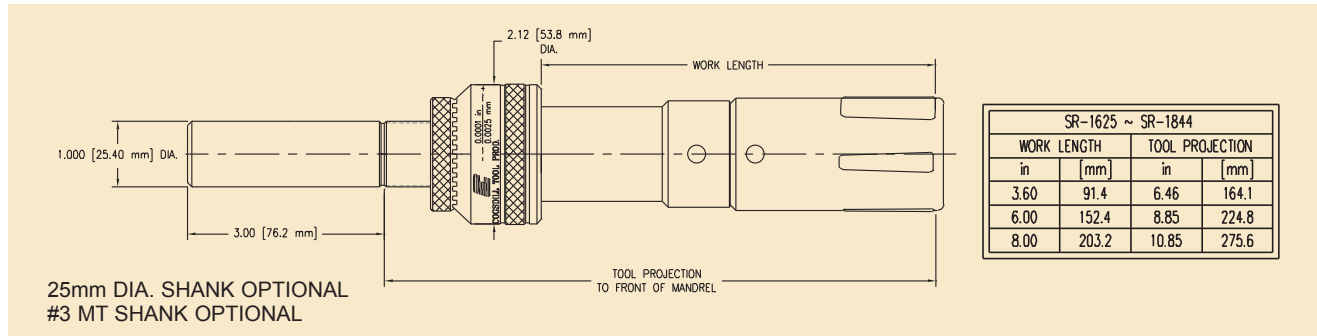

“SR” SERIES ROLL-A-FINISH® TOOLS 1-5/8 TO 1-7/8 IN (41.28 TO 47.63mm)

DIAMETER RANGE		TOOL NUMBER		
INCHES	MM	THRU-HOLE (NO HELIX)	THRU-HOLE (HELIX)	BOTTOMING (NO HELIX)
1.621-1.662	41.17-42.21	SR-1625	SRH-1625	SRB-1625
1.652-1.693	41.96-43.00	SR-1656	SRH-1656	SRB-1656
1.684-1.725	42.77-43.82	SR-1688	SRH-1688	SRB-1688
1.715-1.756	43.56-44.60	SR-1719	SRH-1719	SRB-1719
1.746-1.787	44.35-45.39	SR-1750	SRH-1750	SRB-1750
1.777-1.818	45.14-46.18	SR-1781	SRH-1781	SRB-1781
1.808-1.849	45.92-46.96	SR-1812	SRH-1812	SRB-1812
1.840-1.881	46.74-47.78	SR-1844	SRH-1844	SRB-1844

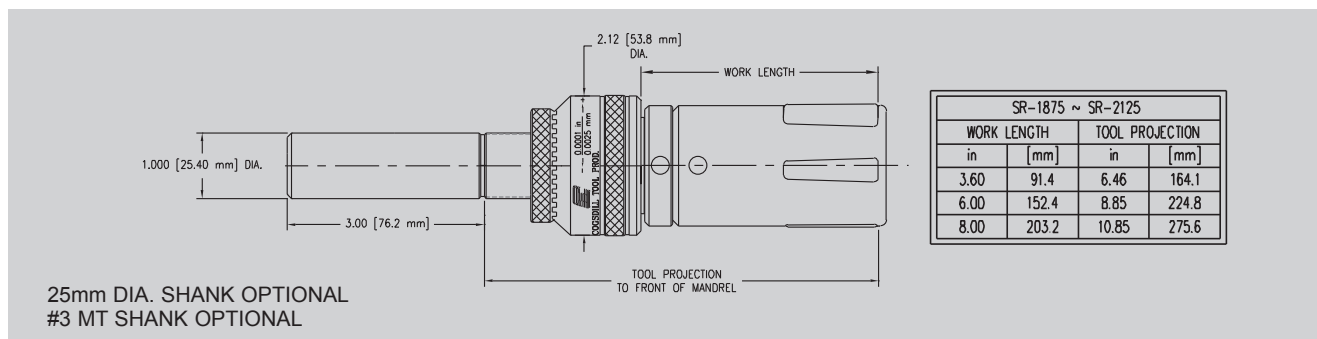

“SR” SERIES ROLL-A-FINISH® TOOLS 1-7/8 TO 2-5/32 IN. (47.63 TO 54.76mm)

DIAMETER RANGE		TOOL NUMBER		
INCHES	MM	THRU-HOLE (NO HELIX)	THRU-HOLE (HELIX)	BOTTOMING (NO HELIX)
1.871-1.912	47.52-48.56	SR-1875	SRH-1875	SRB-1875
1.902-1.943	48.31-49.35	SR-1906	SRH-1906	SRB-1906
1.934-1.975	49.12-50.17	SR-1938	SRH-1938	SRB-1938
1.965-2.006	49.91-50.95	SR-1969	SRH-1969	SRB-1969
1.996-2.037	50.70-51.74	SR-2000	SRH-2000	SRB-2000
2.027-2.068	51.49-52.53	SR-2031	SRH-2031	SRB-2031
2.058-2.099	52.27-53.31	SR-2062	SRH-2062	SRB-2062
2.090-2.131	53.09-54.13	SR-2094	SRH-2094	SRB-2094
2.121-2.162	53.87-54.91	SR-2125	SRH-2125	SRB-2125

Standard Tool specifications

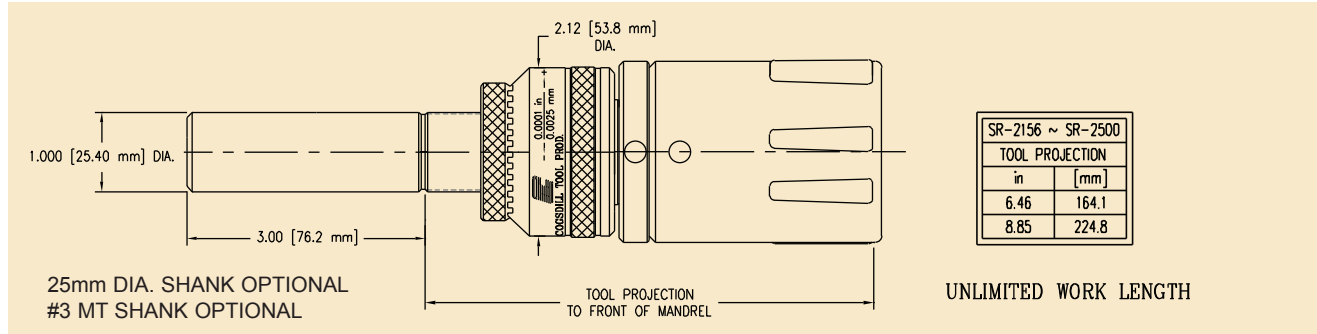

“SR” SERIES ROLL-A-FINISH® TOOLS 2-5/32 to 2-1/2 in. (54.76 to 63.5mm)

DIAMETER RANGE		TOOL NUMBER		
INCHES	MM	THRU-HOLE (NO HELIX)	THRU-HOLE (HELIX)	BOTTOMING (NO HELIX)
2.152-2.193	54.66-55.70	SR-2156	SRH-2156	SRB-2156
2.184-2.225	55.47-56.52	SR-2188	SRH-2188	SRB-2188
2.215-2.256	56.26-57.30	SR-2219	SRH-2219	SRB-2219
2.246-2.287	57.05-58.09	SR-2250	SRH-2250	SRB-2250
2.277-2.318	57.84-58.88	SR-2281	SRH-2281	SRB-2281
2.308-2.349	58.62-59.66	SR-2312	SRH-2312	SRB-2312
2.340-2.381	59.44-60.48	SR-2344	SRH-2344	SRB-2344
2.371-2.412	60.22-61.26	SR-2375	SRH-2375	SRB-2375
2.402-2.443	61.01-62.05	SR-2406	SRH-2406	SRB-2406
2.434-2.475	61.82-62.87	SR-2438	SRH-2438	SRB-2438
2.465-2.506	62.61-63.65	SR-2469	SRH-2469	SRB-2469
2.496-2.537	63.40-64.44	SR-2500	SRH-2500	SRB-2500

Shanks other than shown above are available upon request.

Internal Roll-a-Finish® tools

U series

For hole diameters from 2.500 to 4.000 inches (63.5 to 101.6mm). Work length is unlimited; extension adapters can be used to increase work length.



Offered in *two styles:*

- Through-hole style with helix cage (self-feeding)
- Bottoming-style for blind hole, with no-helix cage (machine-feeding)

...and *available from stock.*

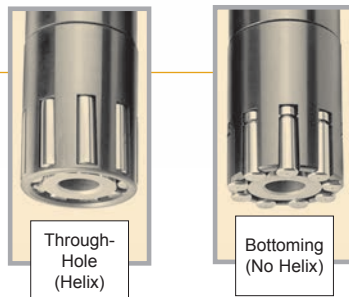

Note: Also available from stock in through-hole, no-helix style.

Standard tool specifications

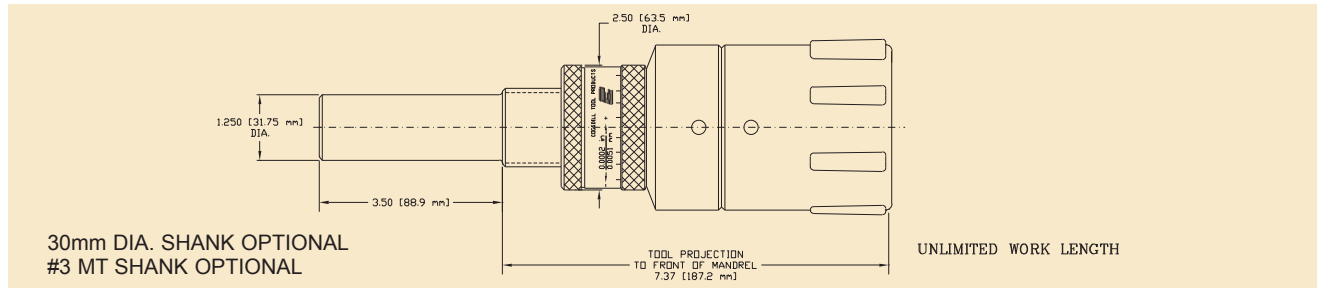

“U” SERIES ROLL-A-FINISH® TOOLS 2-17/32 TO 4 IN. (64.3 TO 101.6 MM)

DIAMETER RANGE		TOOL NUMBER	
INCHES	MM	THRU-HOLE (HELIX)	BOTTOMING (NO HELIX)
2.527-2.568	64.19-65.23	U-2531	UB-2531
2.558-2.599	64.97-66.01	U-2562	UB-2562
2.590-2.631	65.79-66.83	U-2594	UB-2594
2.621-2.662	66.57-67.61	U-2625	UB-2625
2.652-2.693	67.36-68.40	U-2656	UB-2656
2.684-2.725	68.17-69.22	U-2688	UB-2688
2.715-2.756	68.96-70.00	U-2719	UB-2719
2.746-2.787	69.75-70.79	U-2750	UB-2750
2.777-2.818	70.54-71.58	U-2781	UB-2781
2.808-2.849	71.32-72.36	U-2812	UB-2812
2.840-2.881	72.14-73.18	U-2844	UB-2844
2.871-2.912	72.92-73.96	U-2875	UB-2875
2.902-2.943	73.71-74.75	U-2906	UB-2906
2.934-2.975	74.52-75.57	U-2938	UB-2938
2.965-3.006	75.31-76.35	U-2969	UB-2969
2.996-3.037	76.10-77.14	U-3000	UB-3000
3.027-3.068	76.89-77.93	U-3031	UB-3031
3.058-3.099	77.67-78.71	U-3062	UB-3062
3.090-3.131	78.49-79.53	U-3094	UB-3094
3.121-3.162	79.27-80.31	U-3125	UB-3125
3.152-3.193	80.06-81.10	U-3156	UB-3156
3.184-3.225	80.87-81.92	U-3188	UB-3188
3.215-3.256	81.66-82.70	U-3219	UB-3219
3.246-3.287	82.45-83.49	U-3250	UB-3250
3.277-3.318	83.24-84.28	U-3281	UB-3281
3.308-3.349	84.02-85.06	U-3312	UB-3312
3.340-3.381	84.84-85.88	U-3344	UB-3344
3.371-3.412	85.62-86.66	U-3375	UB-3375
3.402-3.443	86.41-87.45	U-3406	UB-3406
3.434-3.475	87.22-88.27	U-3438	UB-3438
3.465-3.506	88.01-89.05	U-3469	UB-3469
3.496-3.537	88.80-89.84	U-3500	UB-3500
3.527-3.568	89.59-90.63	U-3531	UB-3531
3.558-3.599	90.37-91.41	U-3562	UB-3562
3.590-3.631	91.19-92.23	U-3594	UB-3594
3.621-3.662	91.97-93.01	U-3625	UB-3625
3.652-3.693	92.76-93.80	U-3656	UB-3656
3.684-3.725	93.57-94.62	U-3688	UB-3688
3.715-3.756	94.36-95.40	U-3719	UB-3719
3.746-3.787	95.15-96.19	U-3750	UB-3750
3.777-3.818	95.94-96.98	U-3781	UB-3781
3.808-3.849	96.72-97.76	U-3812	UB-3812
3.840-3.881	97.54-98.58	U-3844	UB-3844
3.871-3.912	98.32-99.36	U-3875	UB-3875
3.902-3.943	99.11-100.15	U-3906	UB-3906
3.934-3.975	99.92-100.97	U-3938	UB-3938
3.965-4.006	100.71-101.75	U-3969	UB-3969
3.996-4.037	101.50-102.54	U-4000	UB-4000

Shanks other than shown above are available upon request.