

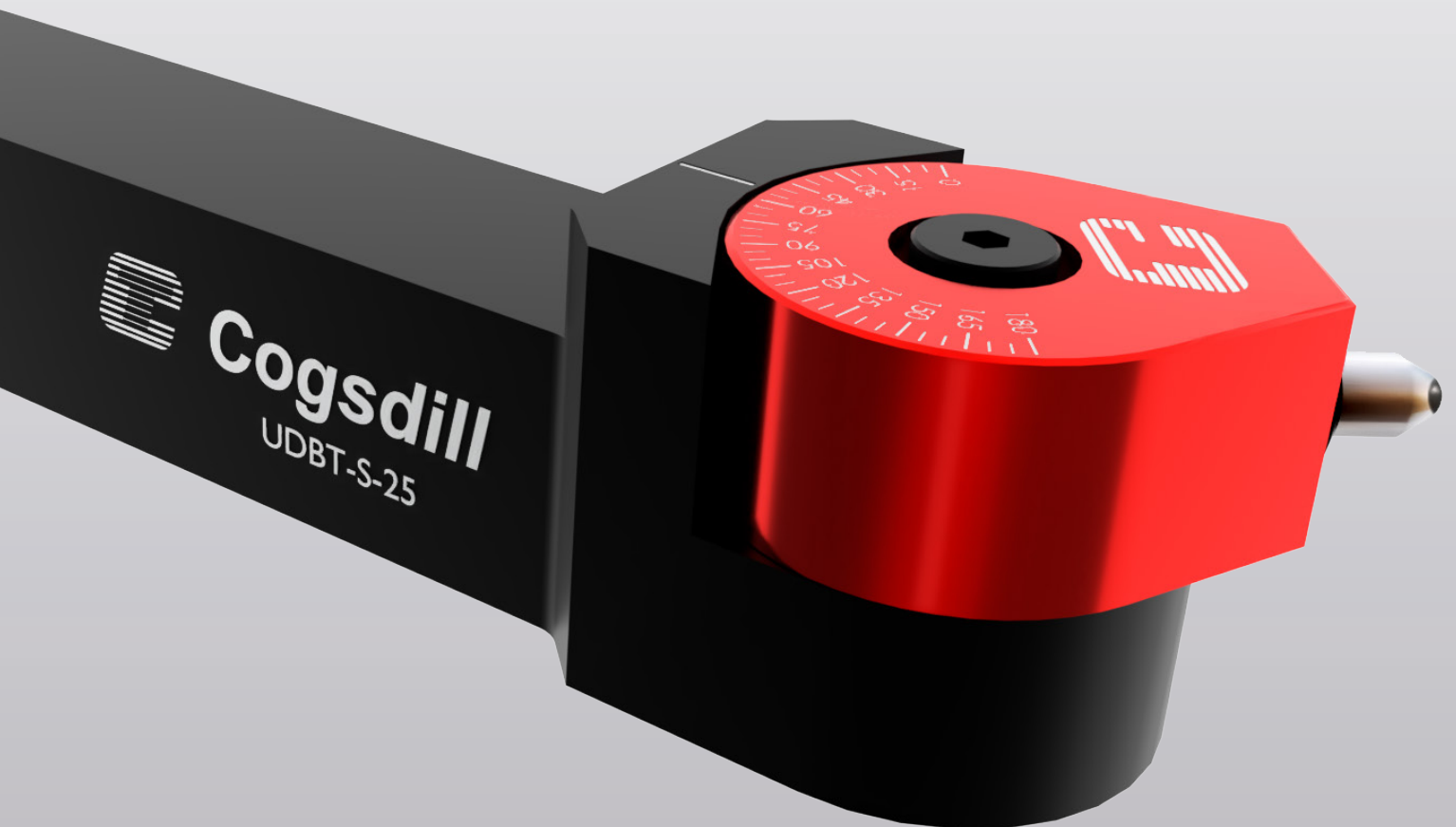

Universal Diamond Burnishing Tools



One Tool. Multiple Applications.

Designed for ultimate versatility within low volume productions.

cogsdill.com

Universal Diamond Burnishing Tools (UDBT)

Universally speaking

Using Cogsdill's proven diamond insert geometry, our premium range of burnishing tools can achieve low Ra surface finishes in one pass – achieving results not attainable from any other metal removal process.

UDBT are designed to be adjustable through 180 degrees, which makes them the ideal choice tool for lower volume batch components where a designated orientated tool is not required.

Offers flexibility for burnishing large bores, outside dia's, tapers and faces – and a superior finish compared to turning alone.

The quick and simple castellated adjustment makes this the most versatile diamond burnishing tool on the market, with simple set-up and no special operator skills required.

There are currently 2 standard models available:

- UDBT-S-25 (Straight Shank with 25mm square section)
- UDBT-C6 (Capto C6 Shank) – which is supplied with through coolant capability

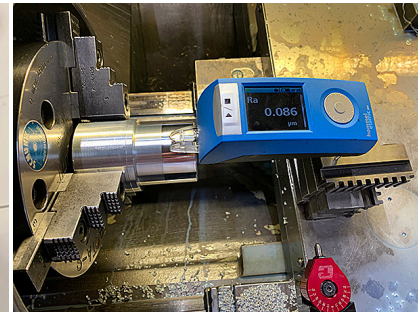
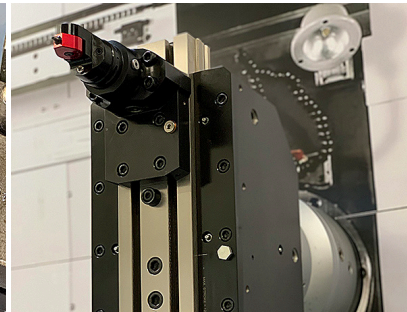
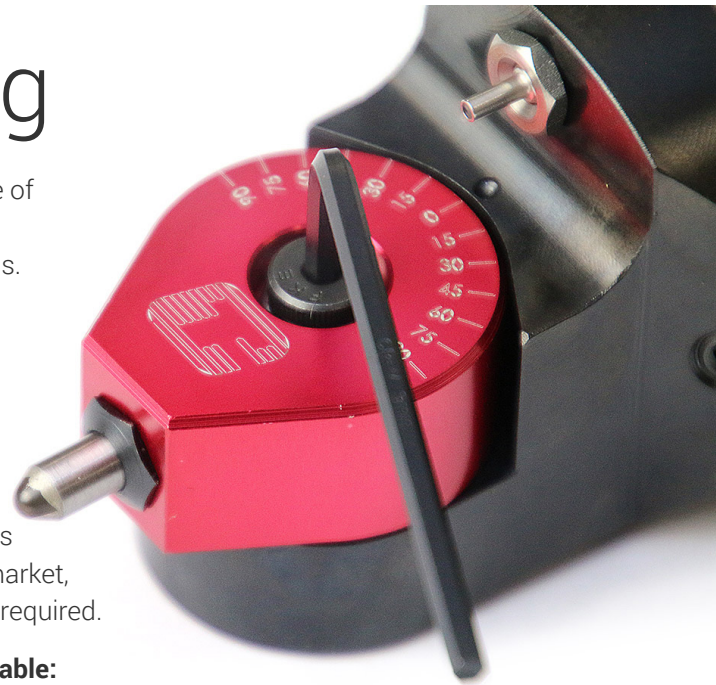

Tool Specifications

UDBT-S-25

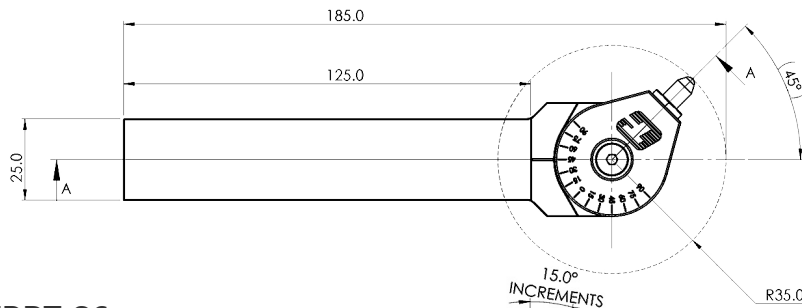

UDBT-C6

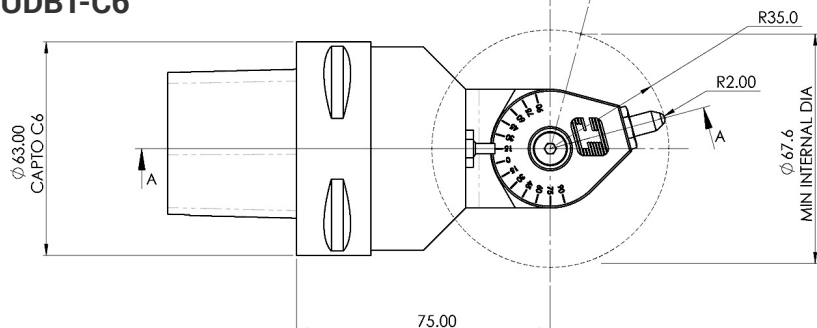

US CORPORATE HQ

Mailing address: P.O. Box 7007
Camden, SC USA 29021-7007

Tel: +1 (803) 438-4000

Fax: +1 (803) 438-5263

Email: cogsdill@cogsdill.com



See this tool
in action on



Connect with us



cogsdill.com